

Intepro Systems

AFV Series

Variable Frequency Power Supply

USER MANUAL

Version History

| Version No. | Release date | Writer | Description | Hardware version applied |
|-------------|--------------|--------|-------------|--------------------------|
| V1.0 | 3-2015 | | Rev 1 | |
| | | | | |
| | | | | |
| | | | | |
| | | | | |

Intepro Systems provides a full range of technical support for our customers. Customers can contact our offices or customer service centers nearby, or our headquarters. All rights reserved. This manual is subject to change without notice.

Safety Precautions

Danger



Beware of the high temperature of this equipment. **DO NOT open the chassis without technician present or authorization from Intepro Systems.**

- When the AFV needs to be moved or rewired, please shut down the instrument completely by disconnecting the input power lines and wait at least 20 minutes for the capacitors in the instrument to discharge to prevent electric shock.
- In order to ensure the personal safety of users, this series of power products must be grounded before use.
- In case of fire, please use dry powder fire extinguishers instead of liquid fire extinguishers to avoid the risk of electric shock.
- Liquid or other foreign objects must not be allowed to enter the cabinet of the grid simulator.

Attention



The application environment and storage methods affect the service life and reliability of the product. Extended use in the following conditions should be avoided:

- Ambient high or low temperatures or humidity beyond technical specifications (temperature: -20°C to 40°C ; relative humidity: 5% to 95%);
- In direct sunlight or exposed to heat sources;
- Places susceptible to vibration or collision;
- Environments with dust, corrosive substances, salt and combustible gases;

Keep the air inlets and outlets unblocked to promote ventilation to avoid a rise in the internal temperature, which may shorten the service life of components, and affect the service life of the product;

Grid simulators not in service for a long time should be stored in a dry environment. The temperature range for storage is -40°C to 70°C .

To properly protect the equipment, only the personnel of Intepro Systems are allowed to open the front door or side cover. If the quality assurance seal is broken, required services will incur charges and warranty is void.

Danger: conditions that may cause serious equipment damages or human casualties.

Attention: Conditions that may cause moderate injuries or damages to equipment.

Content

| | | |
|----------|--|-----------|
| 1 | Product Introduction | 1 |
| 2 | Working Principle | 2 |
| 2.1 | Functional block diagram of complete machine | 2 |
| 2.2 | Description of functional block diagram | 3 |
| 2.3 | Main control circuit | 3 |
| 3 | Transportation and Installation | 4 |
| 3.1 | Transportation precautions | 4 |
| 3.2 | Unpacking inspection | 4 |
| 3.3 | Installation environment requirements | 5 |
| 3.4 | Description of cable connection | 6 |
| 3.5 | Cable wiring | 6 |
| 4 | Product Specifications | 7 |
| 4.1 | Technical specifications | 7 |
| 4.2 | Equipment overview and diagrams | 8 |
| 4.3 | Equipment description | 10 |
| 5 | Operation | 11 |
| 5.1 | Initial power-up of system | 11 |
| 5.2 | Menu description | 11 |
| 5.3 | Parameter setting | 12 |
| 5.3.1 | Start-up | 12 |
| 5.3.2 | User mode | 13 |
| 5.4 | Application interface | 14 |
| 5.4.1 | General Mode | 14 |
| 5.4.2 | Step mode | 15 |
| 5.4.3 | Gradual mode | 16 |
| 5.4.4 | Measurement mode | 17 |
| 5.4.5 | System setting interface | 18 |
| 5.4.6 | System log | 20 |
| 5.5 | RS485 communication | 21 |
| 5.5.1 | RS485 communication wiring | 21 |
| 5.5.2 | RS485 communication | 21 |
| 5.5.3 | File menu | 29 |
| 5.5.4 | System setting | 30 |

| | | |
|----------|--|-----------|
| 6 | Repair and Maintenance | 33 |
| 6.1 | Daily repair and maintenance | 33 |
| 6.2 | Regular maintenance | 34 |
| 7 | Troubleshooting and Solutions | 35 |
| 8 | After-Sales Service | 36 |
| | Warranty | 37 |

Chapter I Product Introduction

The AFV series power supply is a programmable power supply for grid simulation. With advanced SPWM technology and direct digital frequency synthesis (DDS) waveform technology, the power supply has stable output frequency and good continuity. AFV series power supplies provide continuous, pure and stable sinusoidal voltage. They can achieve local control via remote control through the user's PC using internal control and communication modules. The internal electronic circuit can quickly detect over-current, overload, over-voltage and output short circuit, and will automatically protect and cut off the output and sound an alarm. The integrated laminated busbar technology and modular configuration in the power supply inverter unit improve reliability and stability. The touch screen display and control make for easier operation.

The main performance characteristics of the AFV series variable frequency power supplies are as follows:

- Advanced SPWM technology and direct digital frequency synthesis (DDS) waveform technology are used. The power supply has stable output frequency and good continuity;
- The patented inner loop energy-saving test design is used to reduce energy consumption;
- High precision settings and output;
- Comprehensive and stable protection, perfect self-diagnostic maintenance function and higher system reliability;
- The laminated busbar structure is used to effectively reduce the inductance of the inverter circuit and improve the reliability of the inverter;
- Intelligent fan speed regulation control is used with a built-in dust filter to achieve efficient heat dissipation and effective protection in harsh environments;
- Communication interface: Communication using RS485 (standard configuration) and Ethernet (optional configuration);
- A running event recording function records up to 255 events.

Chapter II Working Principle

2.1 Functional block diagram of complete machine

All functional units of the AFV series, from input to output according to the functional sequence, are shown in Fig. 2-1.

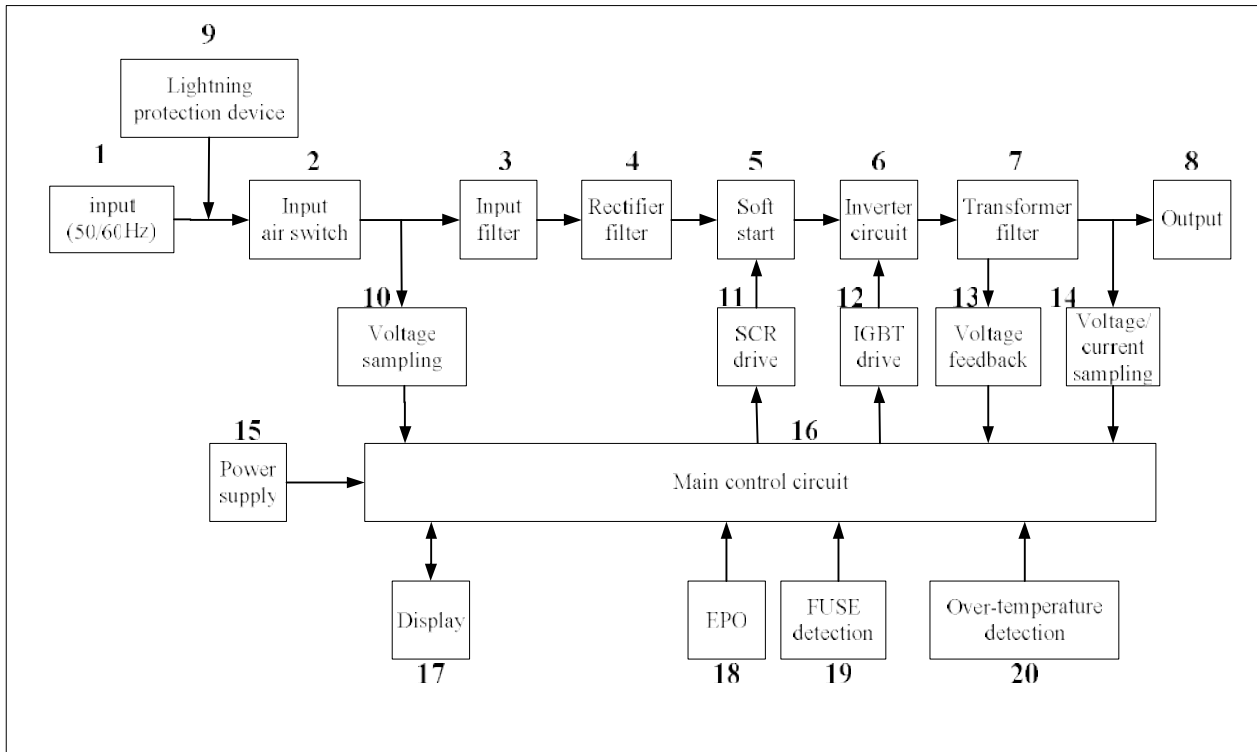

Fig. 2-1 Functional block diagram of complete machine

2.2 Description of functional block diagram

- 1) Input: Connects from the power supply endpoint to the input terminal disk of the equipment.
- 2) Input air switch: Controls the commercial power input equipment.
- 3) Input filter: Input inductor and capacitor filter.
- 4) Rectifier filter: Converts the input alternating current into direct current.
- 5) Soft start: DC capacitor is charged slowly to reduce the impulse current.
- 6) Inverter circuit: Converts the direct current into PWM waveform.
- 7) Transformer filter: Boosts the output voltage of IGBT and outputs the voltage after LC filter.
- 8) Output: The output voltage is transferred to the output terminal disk (or output copper bar) through the contactor.
- 9) Lightning protection device: Over-voltage protection, lightning protection, restraining surge current, absorbing spike pulse, etc.
- 10) Voltage sampling: Input voltage sampling conditioning circuit.
- 11) SCR drive: Drive control circuit of soft start SCR.
- 12) IGBT drive: Amplify PWM signals to drive IGBT power components.
- 13) Voltage feedback: Steadily output voltage amplitude.
- 14) Voltage/current sampling circuit: Sampling conditioning circuit of output voltage and current.
- 15) Power supply: Power supply of all PCB.
- 16) Main control circuit: The processing of all input and output signals.
- 17) Display: Touch screen display.
- 18) EPO: Emergency stop signal.
- 19) FUSE detection: Transmit the FUSE power-off signal to the control circuit for trip protection.
- 20) Over-temperature detection: Transmit the over-temperature signal to the control circuit for trip protection.

2.3 Main control circuit

The main control circuit is divided into three parts: the protection sampling module, the main control module and the display control module. The relationships between these three parts are shown in Fig. 2-2.

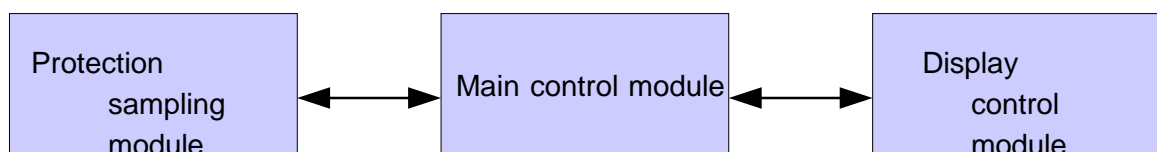

Fig. 2-2 Block diagram of control parts

Chapter III Transportation and Installation

3.1 Transportation precautions

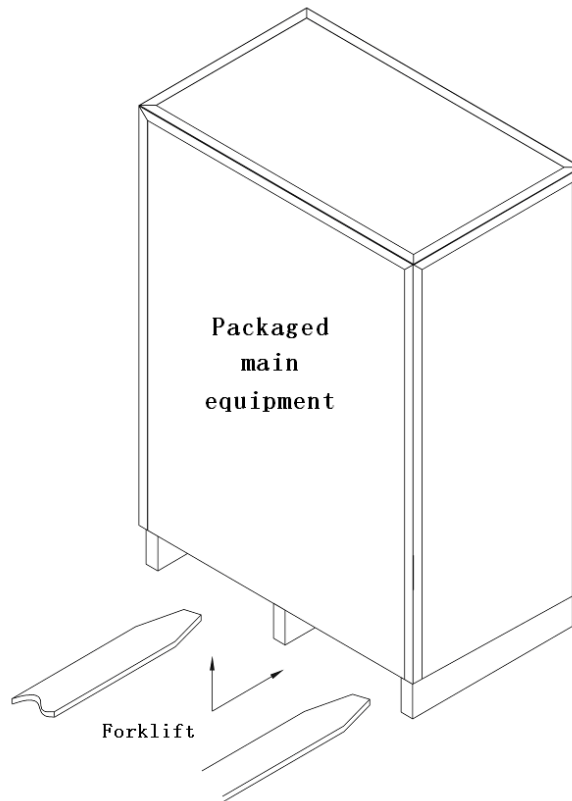

Fig. 3-1 Diagram of transportation

Because the equipment is heavy, the lifting operations need to be slow during the transportation by forklift. This will prevent damaging the equipment itself or the surroundings.

The equipment needs to be fixed firmly during transport to prevent it from sliding or dumping. Although the shockproof packaging was designed for transport, it is recommended that caution should be exercised if driving on rough roads.

3.2 Unpacking Inspection

- When opening the wooden boxes that contain the equipment, pay extra attention to handling. The equipment is heavy. Avoid dropping or dumping.
- Before turning on the equipment check the equipment condition for damage from transport. Inform Intepro Systems staff of any damage.
- Check the accessories shown on the delivery accessory list. If any accessories are missing please contact Intepro Systems as soon as possible.

3.3 Installation Environment Requirements

When selecting where to install, the following should be adhered to:

- 1) Install the equipment indoors and maintain air flow. Try to keep the equipment air inlet/outlet free of dust;
- 2) The surface on which the equipment is installed should have sufficient strength to support the equipment and be as level as possible. The equipment shall not shake once it is in place;
- 3) The equipment adopts the incoming line and the outgoing line. It is recommended to arrange lines and cables connected externally from the cable trenches to facilitate the installation and maintenance;
- 4) Where the equipment is placed should provide sufficient space to allow the heat which is produced by the equipment to vent (see Fig. 3-2). Please do not cover the air inlet on the front panel;
- 5) Do not use the equipment in an environment with dust, volatile or flammable gases, high saline matter or corrosive substances because these may affect the product life;
- 6) Do not place the equipment in an environment with high temperature or humidity. Keep away from water, heat sources and avoid direct sunlight;
- 7) Use correct power distribution to guarantee the safety of the equipment and the user's equipment.

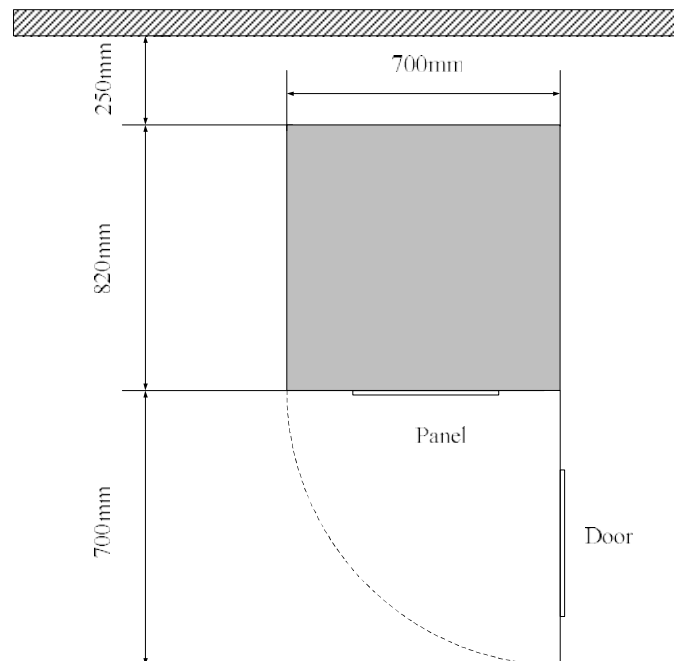

Fig. 3-2 Schematic diagram of bottom of fixing device

3.4 Description of cable connection

The cable connection of the main circuit is as shown:

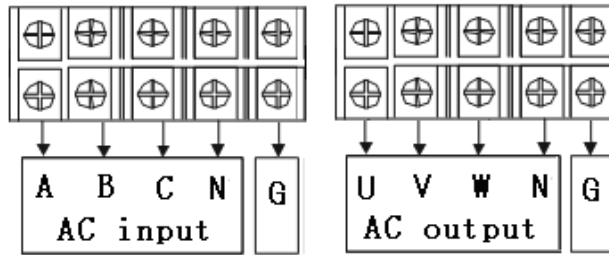

Fig. 3-3 Schematic diagram of wiring terminal

Before installing the equipment, all the switches are to be disconnected. The circuit cables should be connected properly according to the above diagram.

3.5 Cable wiring

- 1) Use a voltmeter to confirm that there is no voltage output in the distribution lines;
- 2) Confirm that all of the switches of the variable frequency power supply are in the “OFF” position;
- 3) The input and output cables can be selected according to the cables recommended by Intepro Systems. Model AFV-33030U is shown as an example in Tables 3-1 and 3-2.

Table 3-1 Reference table of input distribution cables

| Machine model | Input current (A) | Input live wire (mm ²) | | | Input zero line (mm ²) | Input ground wire (mm ²) |
|---------------|-------------------|------------------------------------|-------------------|-------------------|------------------------------------|--------------------------------------|
| | | A | B | C | | |
| AFV-33030U | 70.8A | 25mm ² | 25mm ² | 25mm ² | 16mm ² | 16mm ² |

Table 3-2 Reference table of output distribution cables

| Machine model | Output current (A) | Output live wire (mm ²) | | | Output zero line (mm ²) | Output ground wire (mm ²) |
|---------------|------------------------|-------------------------------------|-------------------|-------------------|-------------------------------------|---------------------------------------|
| | | U | V | W | | |
| AFV-33030U | LO: 83.3A HI: 41.7A | 25mm ² | 25mm ² | 25mm ² | 25mm ² | 16mm ² |

The reference cables recommended in the above-mentioned tables are multi-core flexible copper cables. The user can select different cables according to the input and output current conditions. When the length of the input or output lines exceed 20 meters, it is recommended that the wire diameter of the cable should be doubled.

- 4) Properly connect the input distribution lines to the corresponding wiring terminals at the input terminal of the equipment, and connect the output load lines to the corresponding wiring terminals at the output terminal of the equipment.

Note: The corresponding relationship during wiring is generally A, B and C correspond to the common yellow, green and red; the N wire must be connected properly; DO NOT operate a charged device; when the input and output wiring distance is long, it should be considered that the line voltage drops in the wires.

| Three Phase In - Three Phase Out (100~400kVA) | | | | | | | | |
|---|--|---------------------------------------|---------------------|-----------|-----------|-----------|-----------|-------|
| Model | AFV-33100 | | AFV-33120 | AFV-33150 | AFV-33200 | AFV-33300 | AFV-33400 | |
| Capacity (kVA) | 100 | | 120 | 150 | 200 | 300 | 400 | |
| Circuit Type | IBGT/PWM | | | | | | | |
| Input | Phase | Three | | | | | | |
| | Voltage | 120V/208V, 220V/380V, OR 277V/480V | | | | | | |
| | Voltage range | 220V/380V±15% | | | | | | |
| | Frequency range | 47-63 Hz | | | | | | |
| | Power | 0.9 | | | | | | |
| Max Current (A) w/ full load | 187.1 | 224.5 | 280.6 | 374.1 | 561.2 | 748.2 | | |
| Output | Phase | Three | | | | | | |
| | Wave | Sine | | | | | | |
| | Voltage | Low (V) | 0V-150.0V (L-N) | | | | | |
| | | High (V) | 150.1V-300.0V (L-N) | | | | | |
| | Frequency range | 45-65 Hz Optional 45-500Hz | | | | | | |
| | Frequency regulation | ≤0.01% | | | | | | |
| | Max Current (A) | High (A) | 138.9 | 166.7 | 208.3 | 277.8 | 416.7 | 555.6 |
| Low (A) | | 277.8 | 333.3 | 416.7 | 555.6 | 833.3 | 1111.1 | |
| System | Line Regulation | ≤1 | | | | | | |
| | Load Regulation | ≤1% (linear load) | | | | | | |
| | THD | ≤2% (linear load) | | | | | | |
| | Efficiency | ≥90% | | | | | | |
| | Response Time | ≤2ms | | | | | | |
| | Crest Factor | 3:1 | | | | | | |
| Protection | Electronic circuit trip for over/low voltage, over current, over load, over temperature, and short circuit protection and alarm system | | | | | | | |
| Readings | Display | VFD (Touch Screen Optional) | | | | | | |
| | Voltage | Res.: 0.1V, Accuracy: 0.5%FS+4Counts | | | | | | |
| | Current | Res.: 0.1A, Accuracy: 0.5%FS+4Counts | | | | | | |
| | Frequency | Res.: 0.1Hz, Accuracy: 0.5%FS+4Counts | | | | | | |
| Control Mode | RS-232 | Standard | | | | | | |
| | RS-485 | Standard | | | | | | |
| | GPIB | Optional | | | | | | |
| Safety | Insulation Resistance | 10M ohm (Tested w/ DC 500V) | | | | | | |
| | Voltage Resistance | 1800V 10mA for 1 min (Tested w/ AC) | | | | | | |
| Environment | Cooling System | Fan Cooling, Front to Rear | | | | | | |
| | Temperature | 0°C ~ 45°C | | | | | | |
| | Humidity | 0 ~ 90% (Non-condensing) | | | | | | |
| | Altitude | ≤1500m | | | | | | |
| Case No. | 3 | | 4 | | 5 | | | |
| Weight (lb/kg) | 1579/716 | 1713/777 | 2866/1300 | 3087/1400 | 4851/2200 | 5512/2500 | | |
| Consult factory for power levels above 800kVA | | | | | | | | |

Case No. Dimensions (W x D x H mm / in)

| | |
|---|--|
| 3 | 940 x 820 x 1700 / 37.00 x 32.28 x 66.93 |
| 4 | 1100 x 940 x 1850 / 43.31 x 37.00 x 72.83 |
| 5 | 1400 x 1040 x 2000 / 55.12 x 40.94 x 78.74 |

4.2 Equipment Overview and Diagrams

AFV series products correspond to size according to capacity, and the specific sizes are shown in Table 4-1:

Table 4-1 Equipment sizes

| Machine capacity (kVA) | W (mm) | D (mm) | H (mm) |
|------------------------|--------|--------|--------|
| 15, 20 | 650 | 920 | 1248 |
| 30, 45, 60, 75 | 700 | 820 | 1,620 |
| 100, 120 | 940 | 820 | 1700 |
| 150, 200 | 1100 | 940 | 1850 |
| 300, 400 | 1400 | 1040 | 2000 |
| 500, 600 | 4900 | 1400 | 2050 |
| 800, 1000, 1200 | 6300 | 1500 | 2050 |

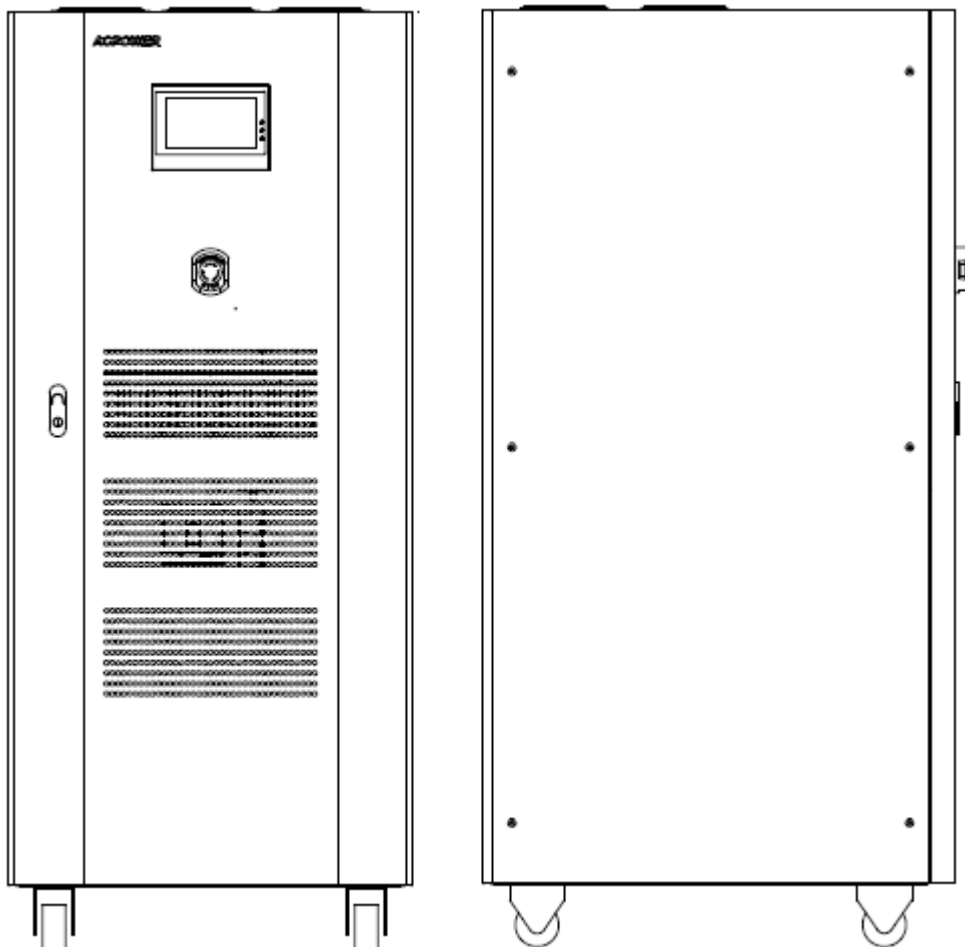

(a) Front view

b) Side view

Fig. 4-1 Cabinet Views

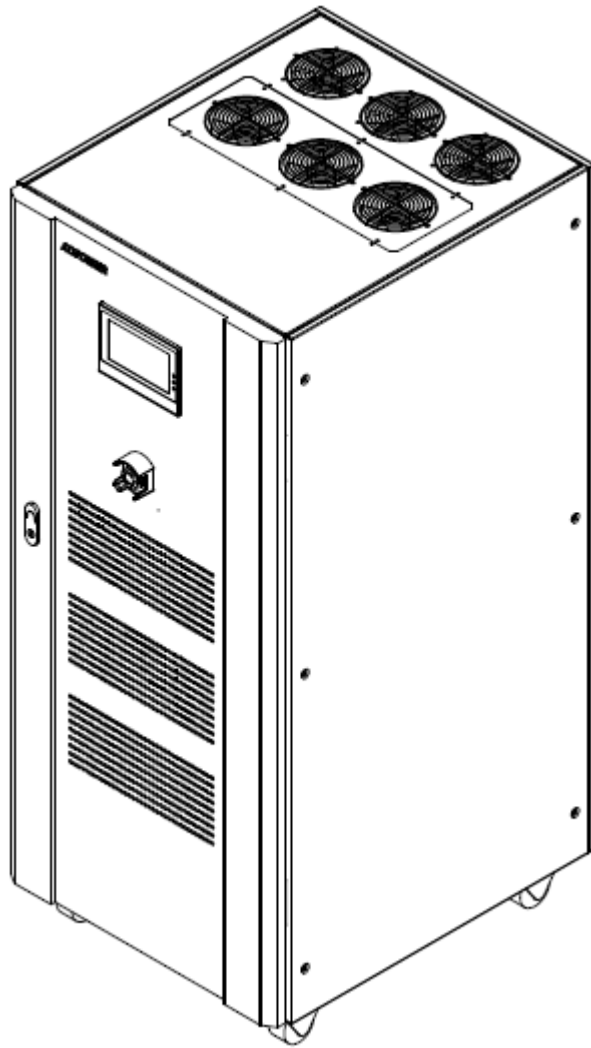

Fig. 4-2 Axonometric view of AFV machine

4.3 Equipment Description

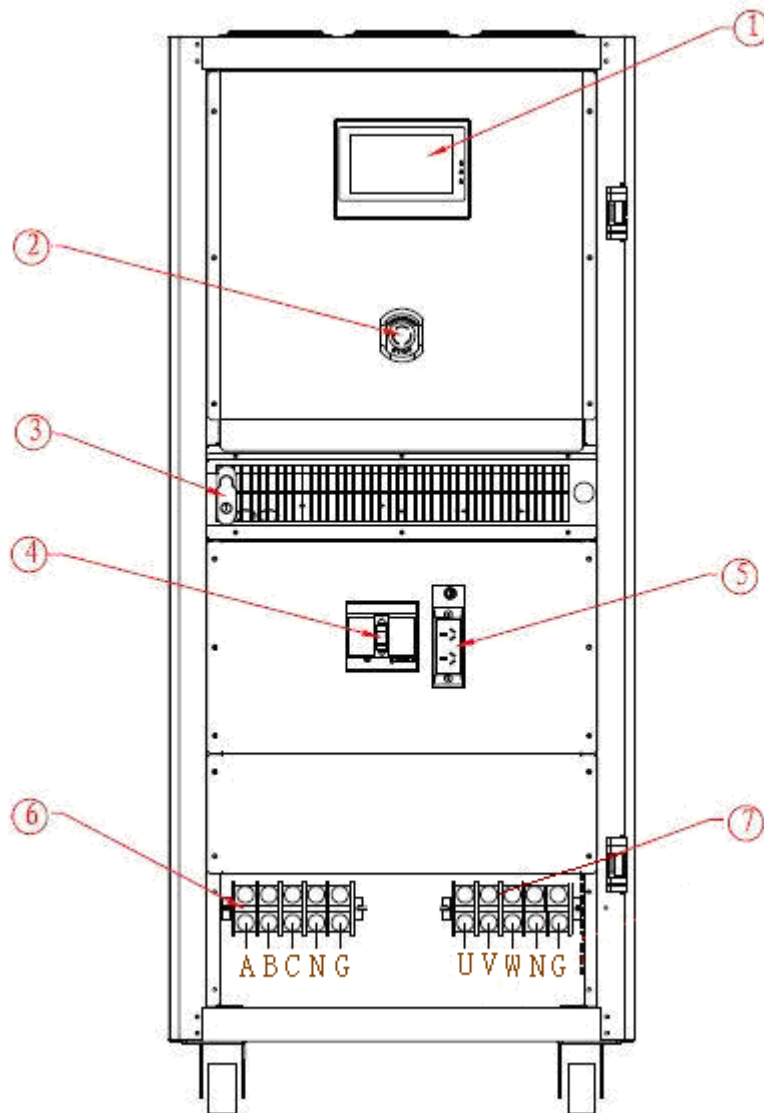

Fig. 4-3 Description of complete equipment appearance

- ① Touch screen;
- ② Emergency stop button;
- ③ Door handle;
- ④ Input air switch;
- ⑤ Maintenance socket;
- ⑥ AC input terminal row;
- ⑦ AC output terminal row .

Chapter V Operation

5.1 Initial power-up of system

The input and output wirings should be properly connected according to the input and output connection shown in Section 3.3. When the system is started, the main engine fan begins to operate and the panel display screen becomes active. Also, the main interface is entered, indicating that the start-up is normal. The parameters can then be set for the machine.

Note: If there is an external load, the load switch should be disconnected first, and the input switch should be connected (it needs to confirm whether the electric power of the input terminal row is normal before the input switch is connected).

The application interface can be entered by clicking “Application”. Users can set the output voltage and frequency value, then press the [Operation] key when completed. Clicking “Meas.” displays the actual output for phase voltage, current, frequency, etc.

5.2 Menu description



Application

The application interface displays phase voltage, current and frequency of output terminal of the AFV(equipment).



System

In the application interface, time setting and system maintenance can be set as required.



Event

Records the historical work information of the equipment.

5.3 Parameter setting

Setting parameters correctly is a basic requirement for running the AFV equipment smoothly. Detailed user modes are described below.

5.3.1 Start-up

When the AFV equipment has been powered on the screen will show the company LOGO as in Fig. 5.1.

5-1.



Fig. 5-1 Start-up interface

The initialization interface is shown in Fig. 5-2.

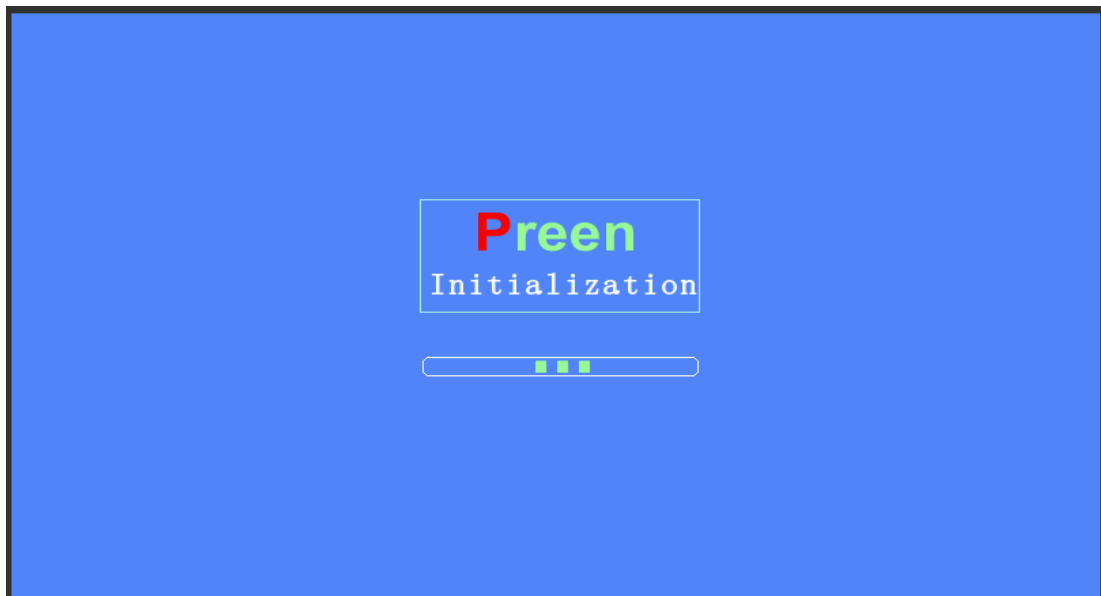

Fig. 5-2 Initialization interface

5.3.2 User mode

Enter the main menu of the user mode. The interface display is shown in Fig. 5-3.



Fig. 5-3 Main menu of user mode

- **【APP】** --Application: Enter the operation setting interface;
- **【SYSTEM】** : Enter the time setting and system maintenance interface;
- **【EVENT】** : Enter the equipment work record information table interface.

5.4 Application interface

In the application interface, users can conduct the operations of the general mode, Step mode, Gradual mode and Measurement mode of the equipment.

Note: All the product information in the operation interface of the equipment should comply with the model specifications of the actual equipment.

5.4.1 General Mode

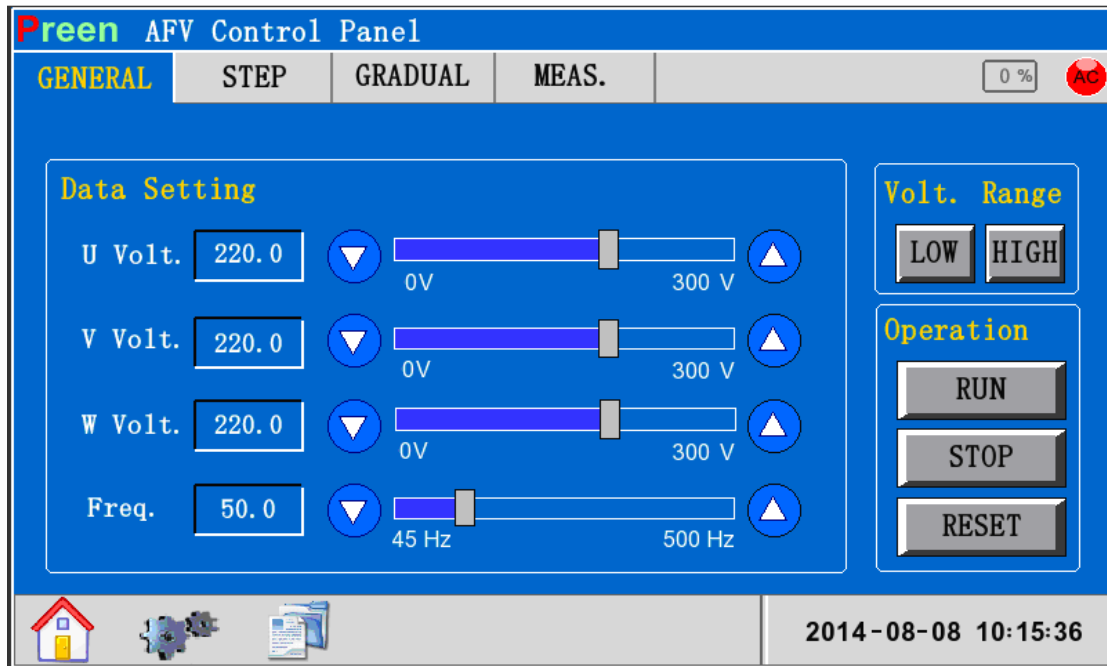

Fig. 5-4 Setting interface of general mode

- 【U Volt.】 / 【V Volt.】 / 【W Volt.】 -- U-phase voltage/ V-phase voltage/ W-phase voltage:
The following three ways can be used for setting voltage at all phases:
 - a) Directly input the voltage value in . Click the box to pop up the keyboard, and then input the voltage value;
 - b) In the box of , touch left and right for adjustment;
 - c) Select & to conduct the setting. The variation unit is 0.1.
- 【Freq】 -- Frequency: Doing the setting is the same as that of voltage;
- 【LOW】 : The equipment starts to output the low voltage when selected;
- 【HIGH】 : The equipment starts to output the high voltage when selected;
- 【RUN】 : The equipment starts the output according to the set value when selected;
- 【STOP】 : The equipment stops the output when selected;
- 【RESET】 : The equipment restores the initial state when selected;
- 【AC】 : AC indicator light displays the operational state of the AC output of the equipment:
Red represents that the mode of the equipment is in the stop state, while green represents that the mode of the equipment is running.

5.4.2 Step mode



Fig. 5-5(a) Step mode setting interface

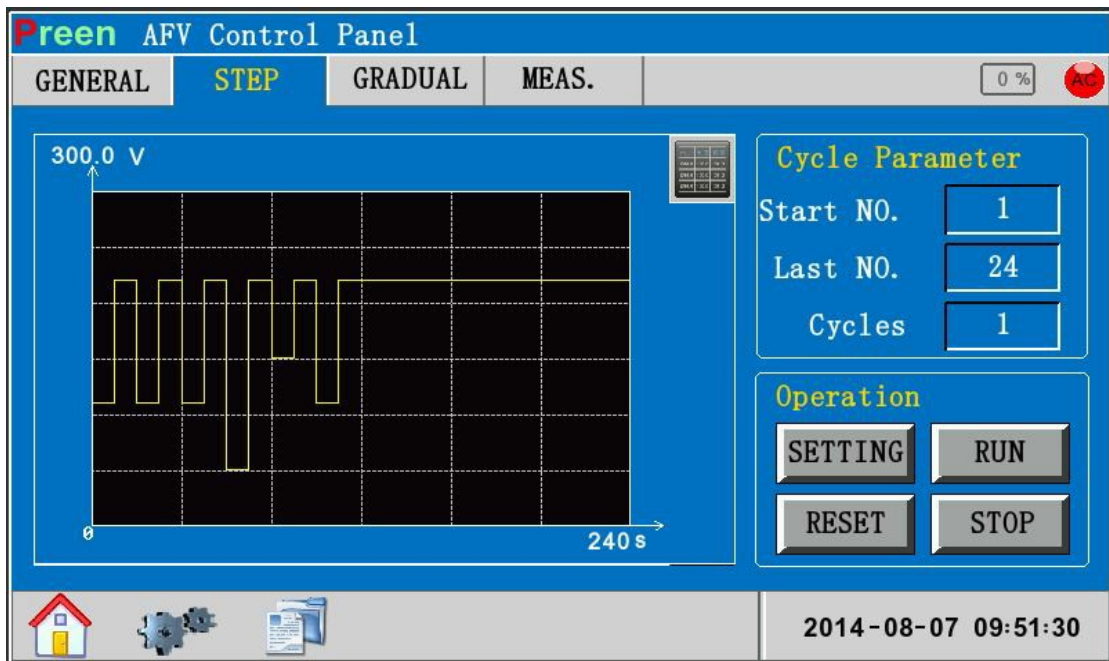

Fig. 5-5(b) Step mode effect interface

- **【SETTING】** : Download the set parameters;
- **【RUN】** : The equipment starts to run the step mode when selected;
- **【RESET】** : The equipment restores the initial state when selected;
- **【STOP】** : The equipment stops running the step mode when selected;
- & : Switch over step setting interface and step effect interface.

5.4.3 Gradual mode



Fig. 5-6(a) Gradual mode setting interface

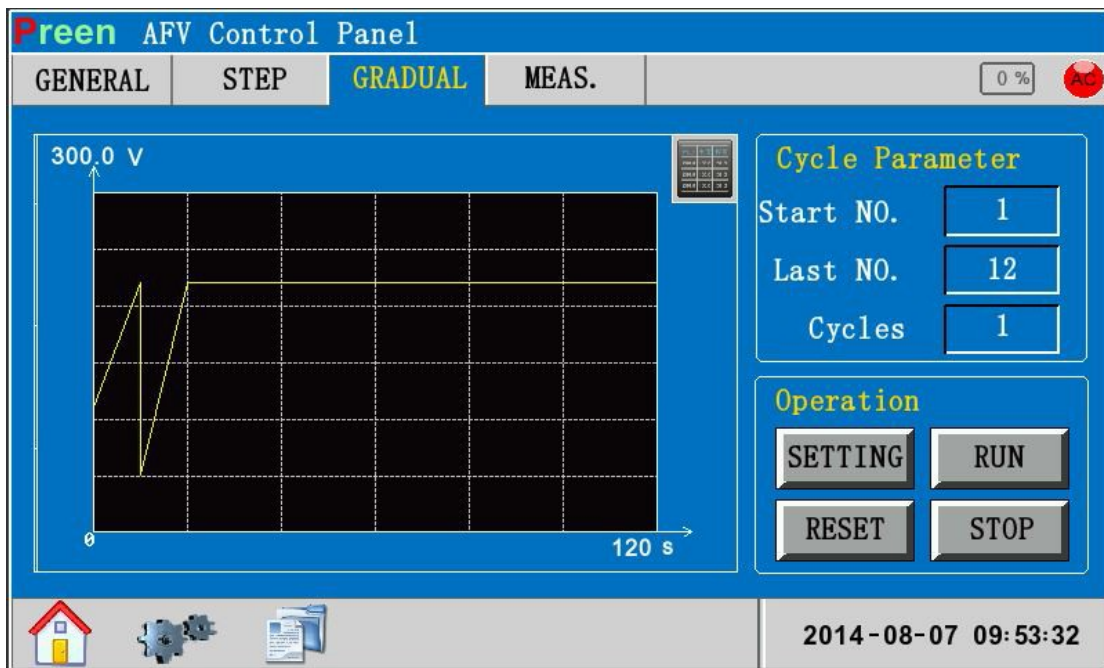



Fig. 5-6(b) Gradual mode effect interface

- **【SETTING】** : Download the set parameters;
- **【RUN】** : The equipment starts to run the gradual mode when selected;
- **【RESET】** : The equipment restores the initial state when selected;
- **【STOP】** : The equipment stops running the gradual mode when selected;
-  &  : Switch over gradual change setting interface and gradual change effect interface.

5.4.4 Measurement mode

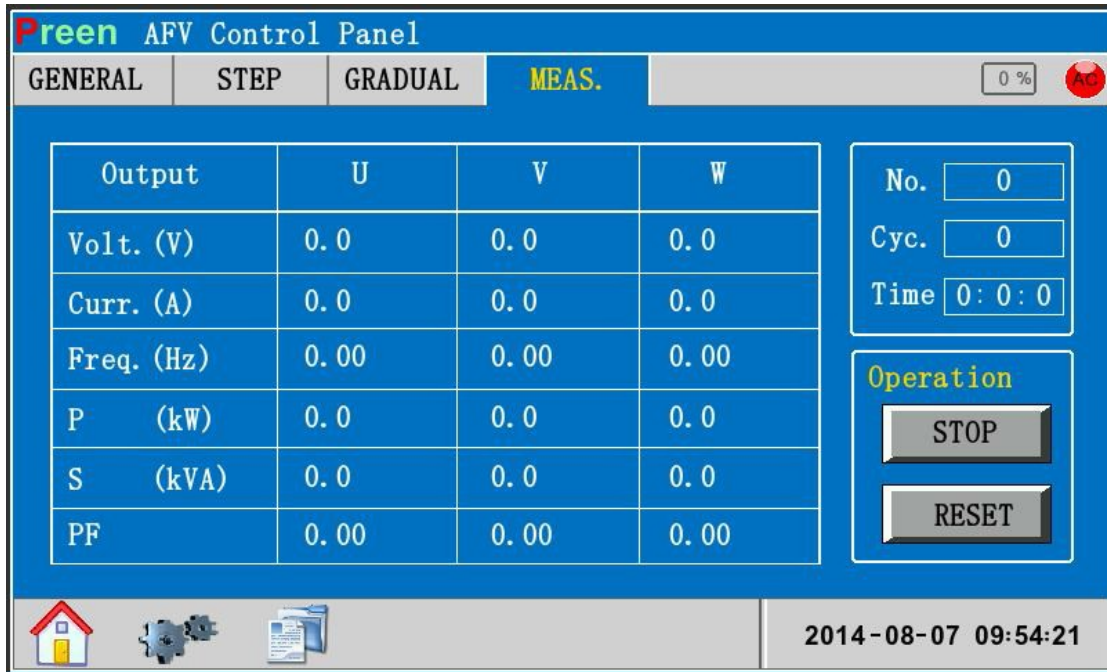

Fig. 5-7 Real-time acquisition interface

- **【MEAS.】** --Measurement: Real-time acquisition;
- **【STOP】** : The equipment stops the output when selected;
- **【RESET】** : The equipment restores the initial state when selected;

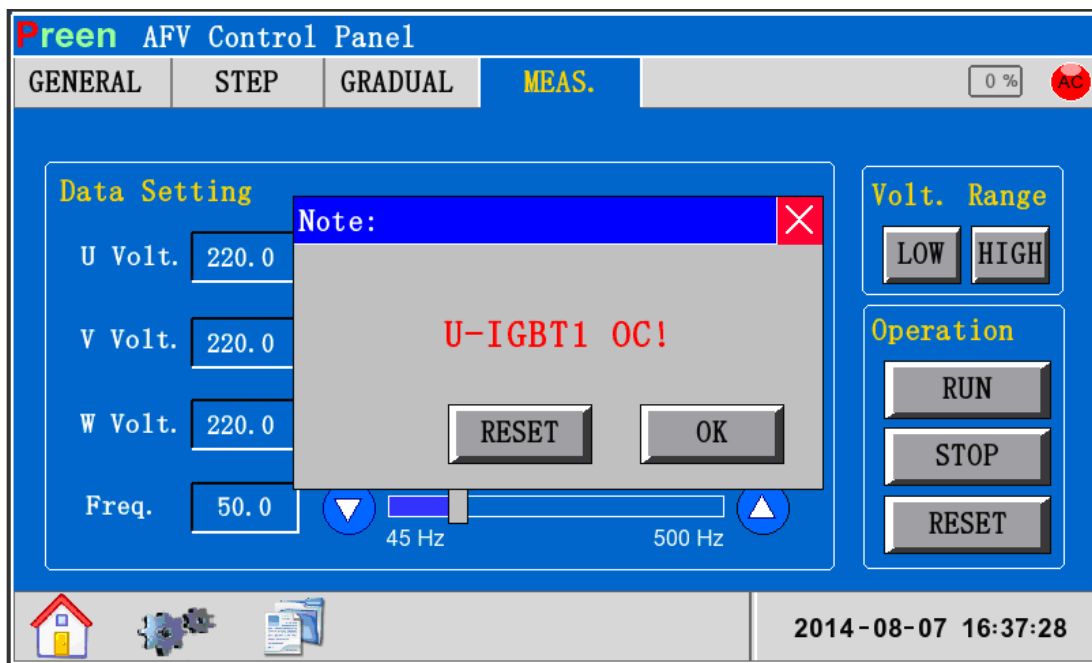

Fig. 5-8 Fault alarm interface

- **【RESET】** : Fault reset;
- **【OK】** : Select to return to the real-time acquisition interface.

5.4.5 System setting interface

The system setting interface is shown in Fig. 5-9.

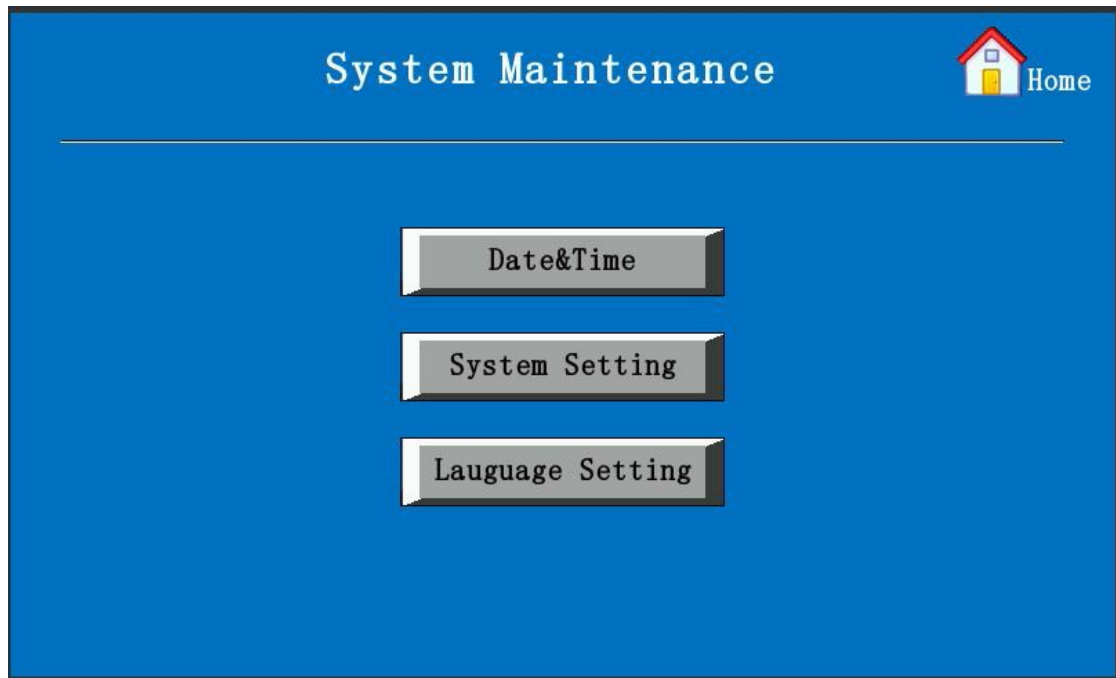

Fig. 5-9 System setting interface

- **【Date&Time】** : Select to enter the date and time settings;
- **【System Setting】** : Under normal circumstances, the system configuration is only for the users to view, and it cannot be modified. If there is a need to modify the system configuration, please contact Intepro Systems customer service personnel;
- **【Language Setting】** : Select to enter the language setting.

The time setting interface is shown in Fig. 5-10 (a). The language setting is shown in Fig. 5-10 (b).

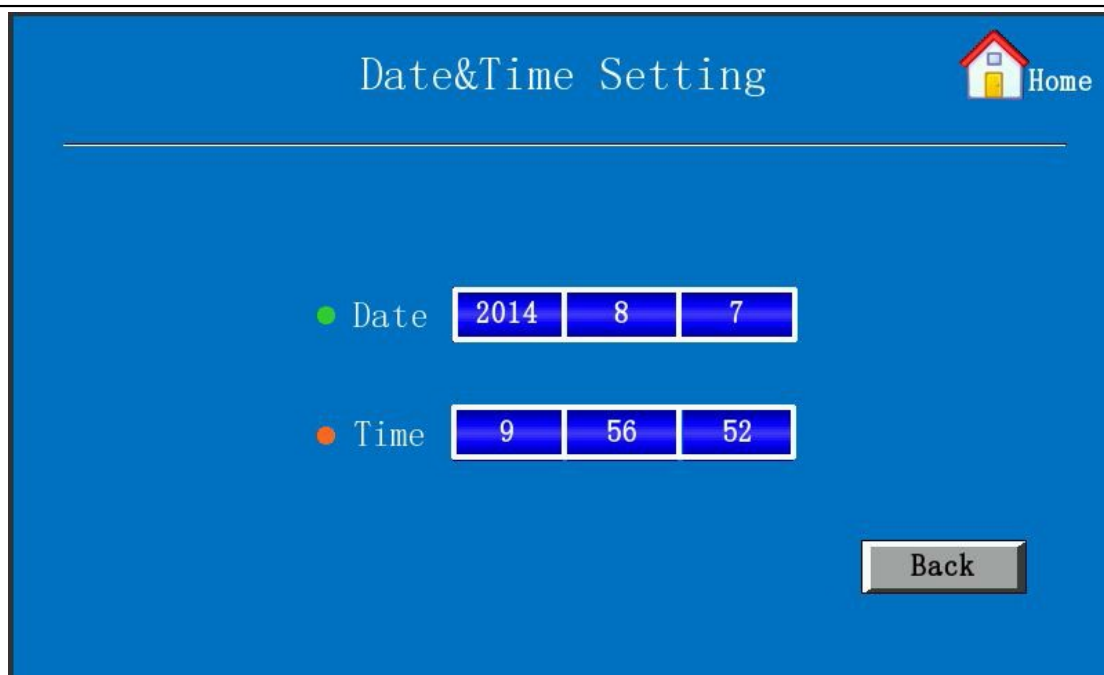

Fig. 5-10 (a) Date&Time setting interface

- **【Date】 / 【Time】** : Input the date and time of the equipment through the digital keyboard;
- **【Back】** : Click it to back the previous interface;
- **【Home】** : Click it to back the main interface.



Fig. 5-10 (b) Language setting interface

- **【简体中文】/【繁體中文】/【English】**: There are three language settings: Simplified Chinese, Traditional Chinese and English;
- **【Back】** : Click it to go back to the previous interface;
- **【Home】** : Click it to return to the main interface.

5.4.6 System log

The system log interface is shown in Fig. 5-11.

| NO. | Date&Time | Content |
|-----|---------------------|---------------------|
| 00 | 2014-08-07 13:47:57 | Reset! |
| 01 | 2014-08-07 13:46:48 | Stop! |
| 02 | 2014-08-07 13:46:46 | Stop! |
| 03 | 2014-08-07 13:46:46 | Gradual Run! |
| 04 | 2014-08-07 13:46:43 | Step Run! |
| 05 | 2014-08-07 13:46:41 | General Run! |
| 06 | 2014-08-07 13:43:00 | Output Volt. Over! |
| 07 | 2014-08-07 13:42:58 | Output Volt. Under! |
| 08 | 2014-08-07 13:42:55 | W Overload! |
| 09 | 2014-08-07 13:42:55 | V Overload! |

1/4

Fig. 5-11 System log setting interface

- **【Previous】 / 【Next】** : Browse the historical event contents;
- **【Clear】** : Empty the system log table;
- **【Back】** : Return to the previous menu.

5.5 RS485 communication

5.5.1 RS485 communication wiring

The AFV(equipment) is provided with a RS485 communication function, and the port is shown below. A RS232 communication cable and a RS232 isolation module are also supplied with the device.



Fig. 5-12 Diagram of RS485 port

■ Note

Descriptions of Touch screen Pins: 1 pins——B, 5 pins——FG, 6 pins——A.

5.5.2 RS485 communication

5.5.2.1 Main interface

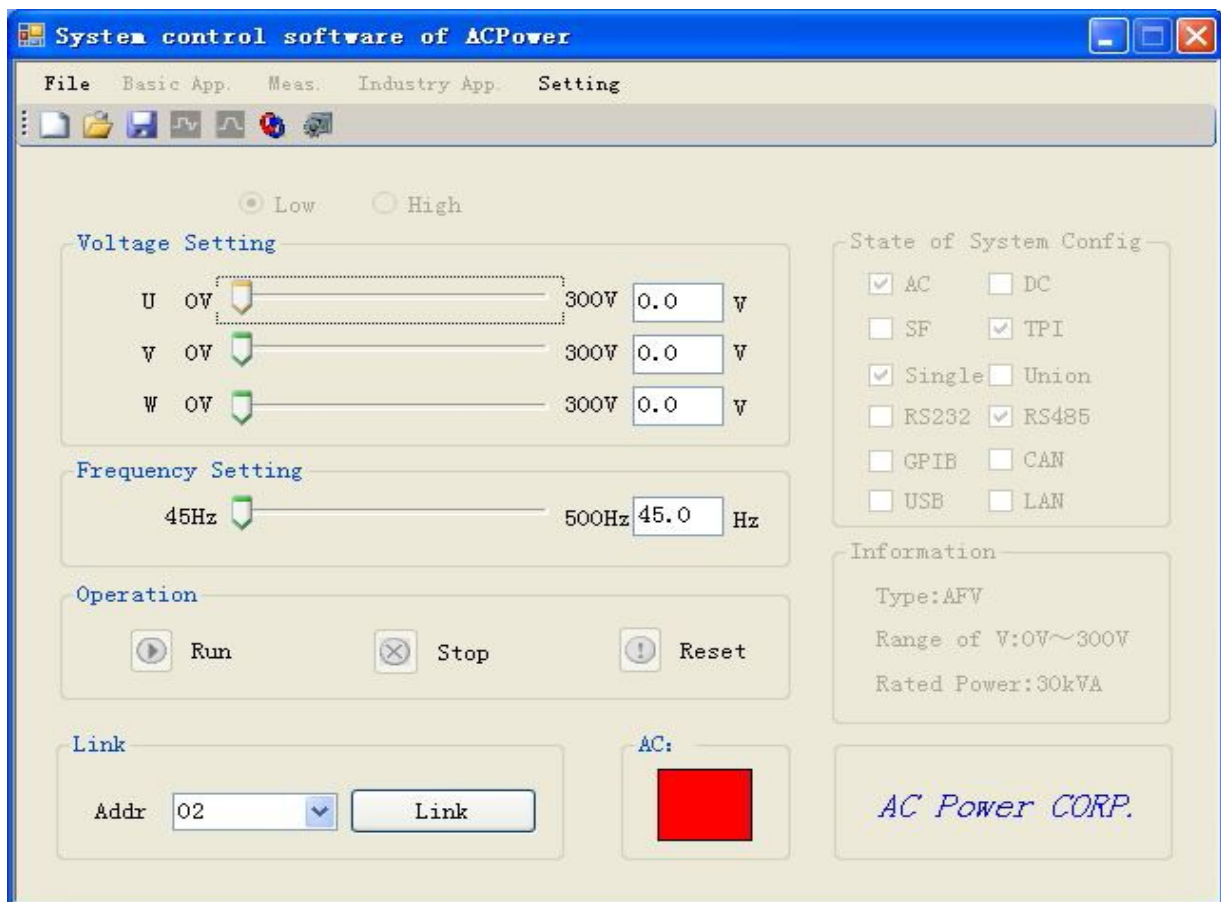

Fig. 5-13 Main interface of upper computer

After running ACPower.exe the main interface shown in the above figure will appear, indicating that the procedure is running normally. If the following message box appears:

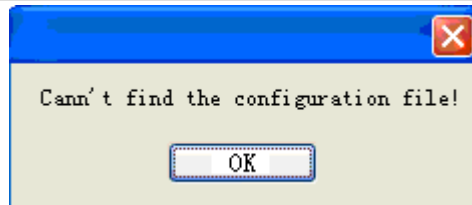

Fig. 5-14 Files configuration message box

This message box indicates that the proper system configuration files are not found. To correct, users should select **【Load Config】** on the **【File】** menu, as shown in the following figure:

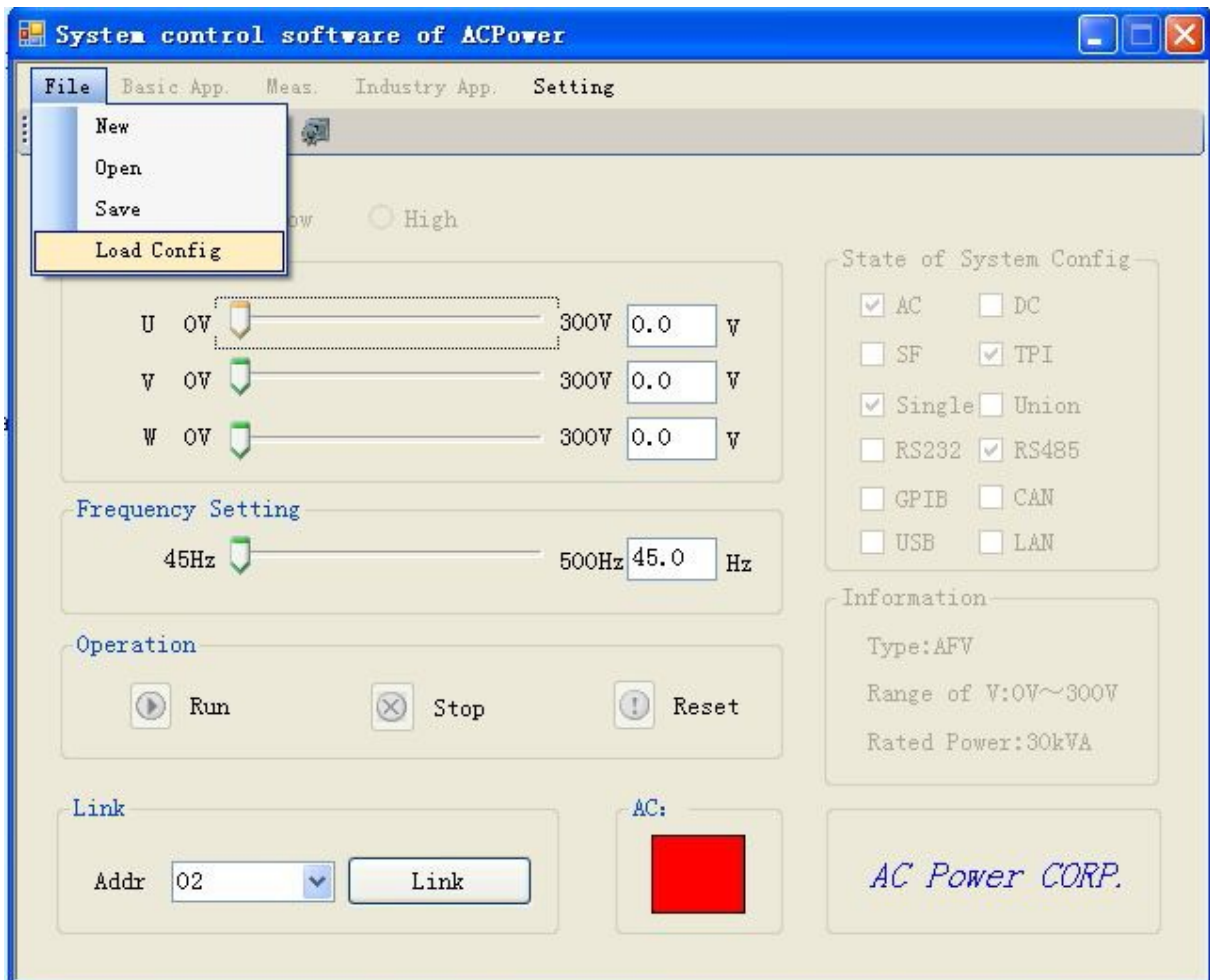

Fig. 5-15 File import configuration menu

Users can import the configuration files (e.g. AFV.cfg) for their power supply model from the CD supplied with the variable frequency power supply. ***For additional inquiries please contact Intepro Systems.***

- **【Link】** : Connecting device;
- **【Run】** : When selected the equipment starts the output according to the set value;
- **【Stop】** : The equipment stops the output when selected;
- **【Reset】** : The equipment restores the initial state when selected;

- **【Basic App.】** -- Basic Application: Includes the Basic Application, Step and Gradual;
- **【Meas.】** -- Measurement : Real-time Sampling;
- **【Industry App.】** -- Industry Application;

Users will next enter the main interface. Before the **【Link】** operation is done with the variable frequency power supply, make sure the controlling buttons **【Run】** , **【Stop】** , **【Reset】** are grey and in the inoperable state. The menus of **Basic Application**, **Measurement**, **Industry Application** and other menus are also grey and in an inoperable state.

User can select **【Link】** in the main interface to open the communication connection with the variable frequency power supply. The main interface will eliminate the grey state when the connection is successfully established, as shown in the following figure:

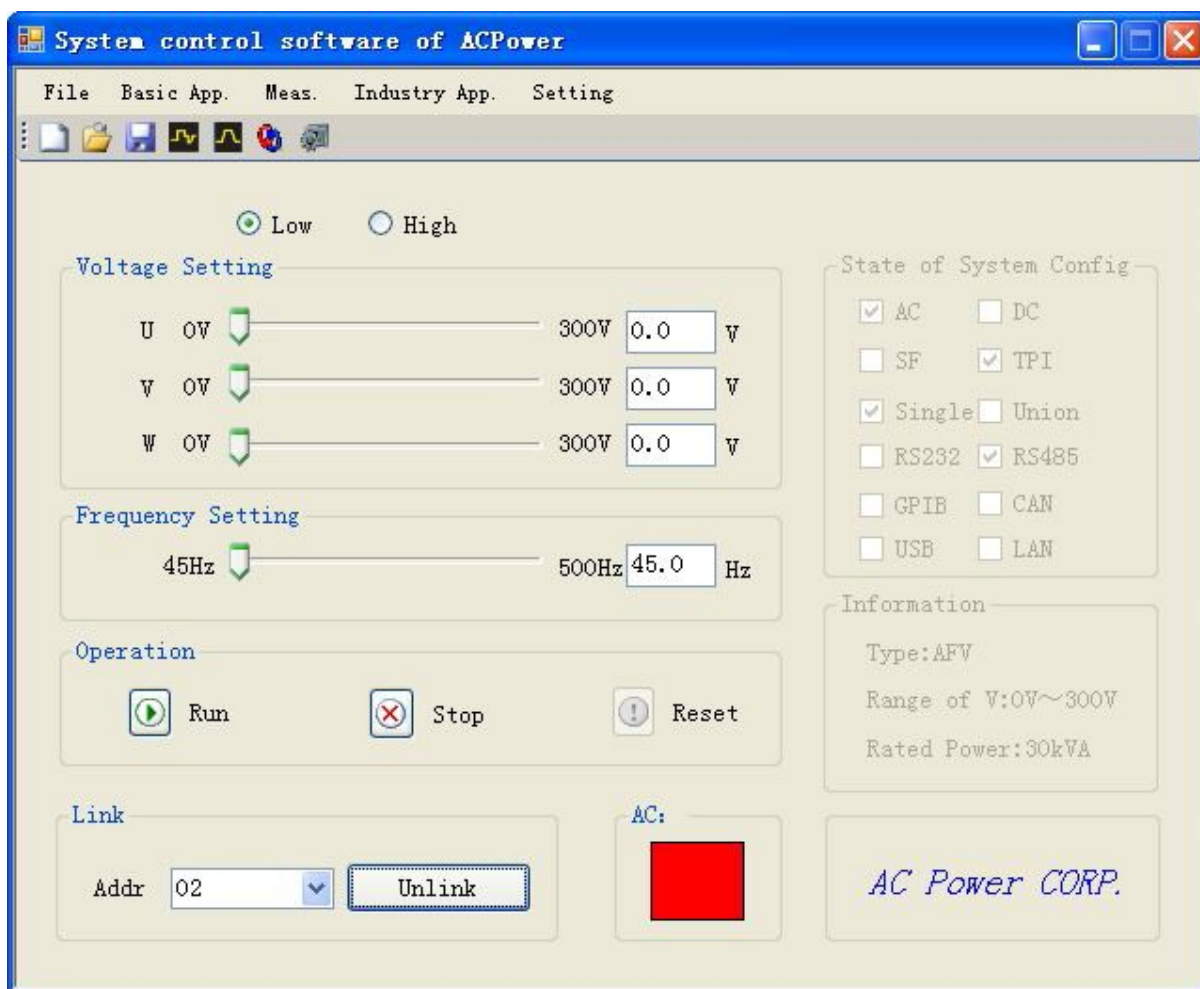

Fig. 5-16 Basic application

In the main interface (the system configuration state), product information and the functions of toolbar and basic applications menu are all displayed. The information is from the imported system configuration files and includes the max./min. value of voltage and frequency.

Only Intepro Systems can modify and update the system configuration files.

5.5.2.2 Step

On the application interface, select the [Step] option to enter the Step function interface:

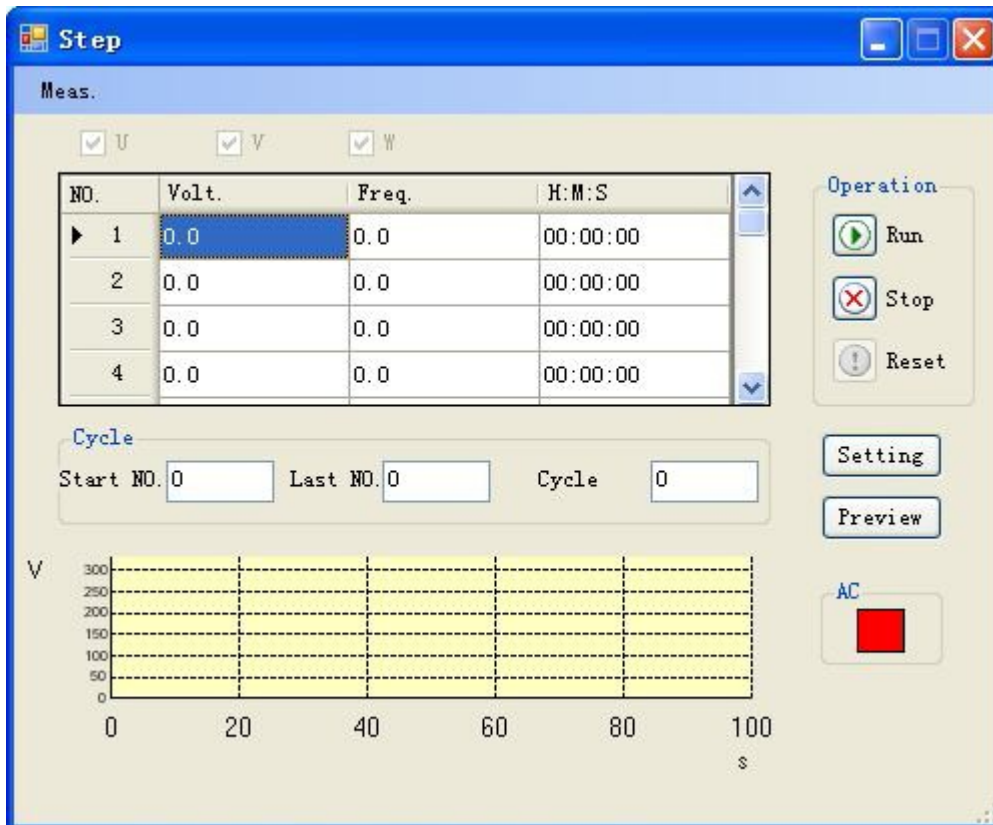

(a) Step function setting interface

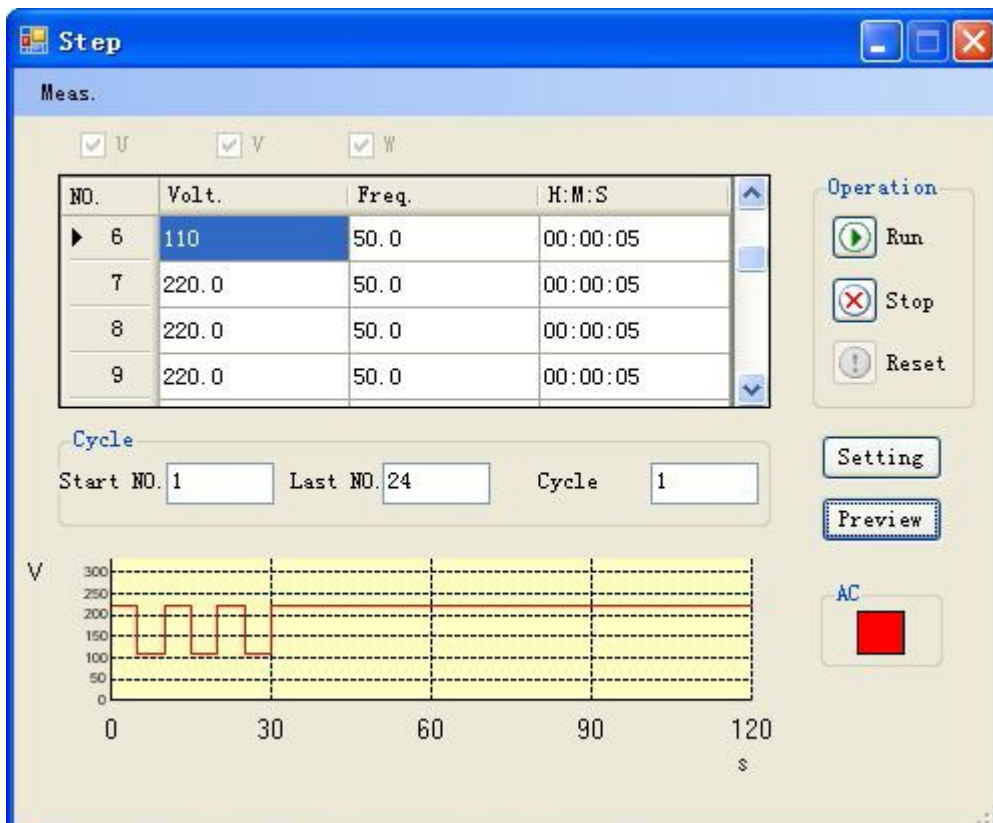

(b) Step function setting interface - preview

Fig. 5-17 Step function interface in remote control

-
- U, V, W three-phase selection: When the independently adjustable three-phase output functions are unavailable, this option is unavailable and appears grey;
 - The maximum number of user-defined data groups can be set up is 24; the maximum number of user-defined data cycles that can be set up is 255;
 - [Preview] button shows a visual simulation of user-defined data;
 - Select the [Setting] button to download user-defined data to the AC power supply;
 - User-defined data will be automatically updated and saved after [Preview] button or [Setting] button or [Run] button is selected;
 -  Status Indicator: Red indicates that the device AC / DC is stopped; green indicates that the device AC / DC is in the output state;
 -

NOTE: User-defined data is not saved until the [Preview] button or [Setting] button or [Run] button is pressed.

- **【Run】** : The equipment starts to run the step mode when selected;
- **【Stop】** : When selected the equipment stops running the step mode;
- **【Reset】** : Selecting this restores the initial state.

5.5.2.3 Gradual

On the application interface, select the [Gradual] option to access the gradual function interface:

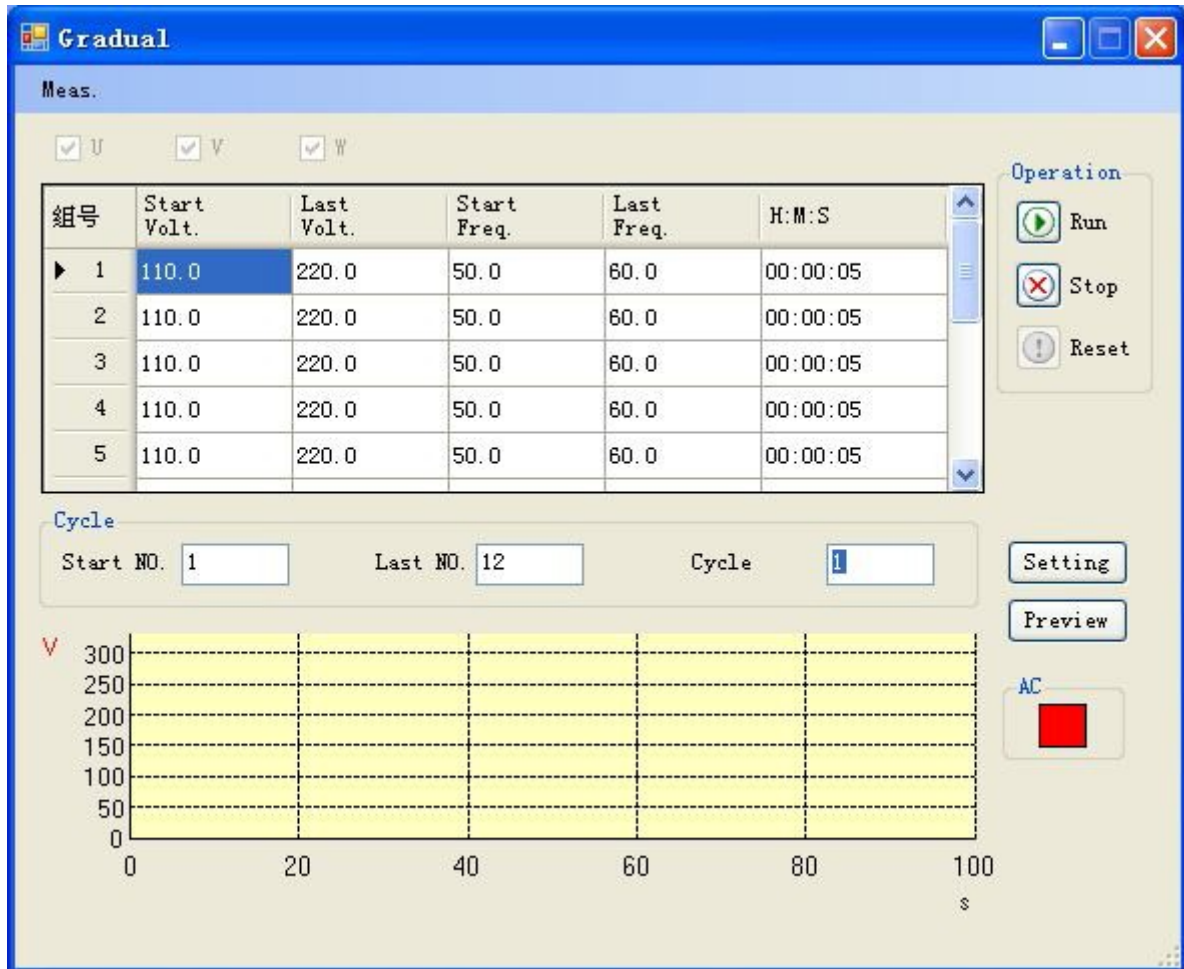

(a) Gradual function setting interface

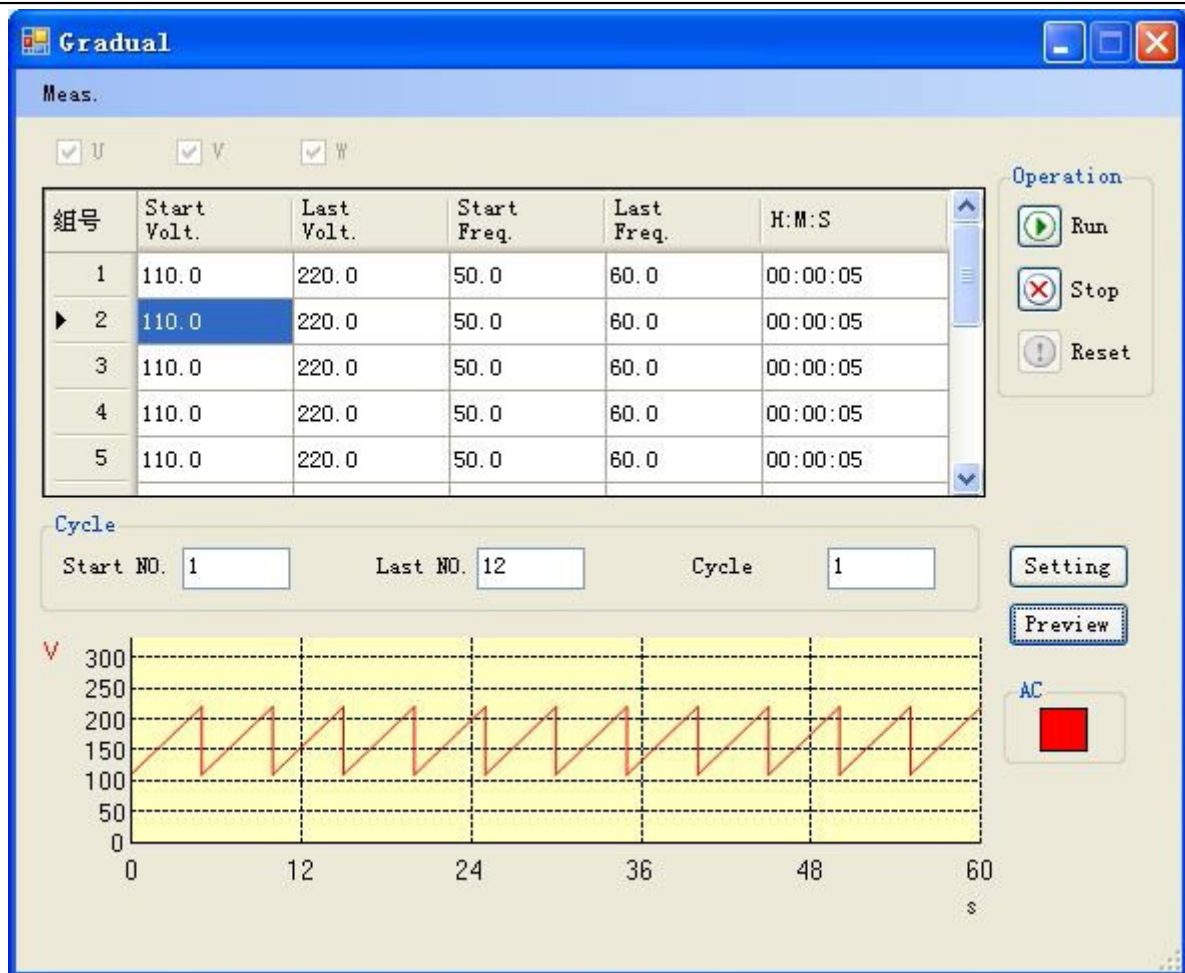

(b) Gradual function setting interface - preview

Fig. 5-18a, b. Gradual function interface in remote control

- The maximum number of user-defined data groups that can be set is 12; the maximum number of user-defined data cycles that can be set is 255;
- Select the [Preview] button to show visual simulation of user-defined data;
- Choose the [Setting] button to download the user-defined data to the AC power supply;
- User-defined data will be automatically updated and saved when the [Preview] button or the [Setting] button or the [Run] button is selected;

NOTE: User-defined data is not saved until the [Preview] button or the [Setting] button or the [Run] button is pressed.

- **【Run】** : The equipment starts to run the gradual mode when selected;
- **【Stop】** : The equipment stops running the gradual mode when selected;
- **【Reset】** : When selected the equipment restores the initial state.

5.5.2.4 Measurement

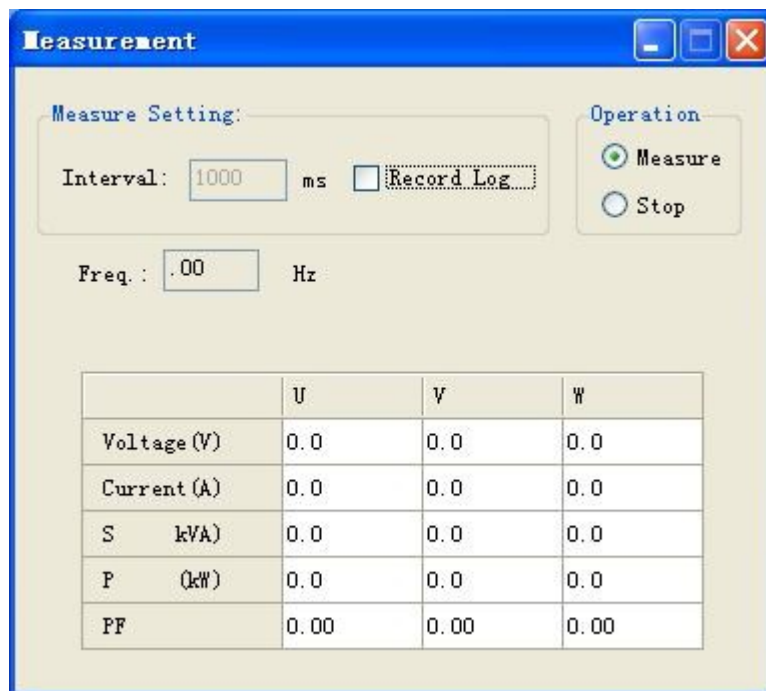

Fig. 5-19 Real-time Sampling

The real-time interface can be entered only when the software is running.

- The sampling interval may be set within the range from 1000 to 5,000ms while the default interval may be set to be 1,000ms;
- The user can choose whether to record the real-time sampling of data and save it as log file;
- The user can select which data items need to be collected real-time;
- The user can control or stop the sampling procedure.

5.5.3 File menu

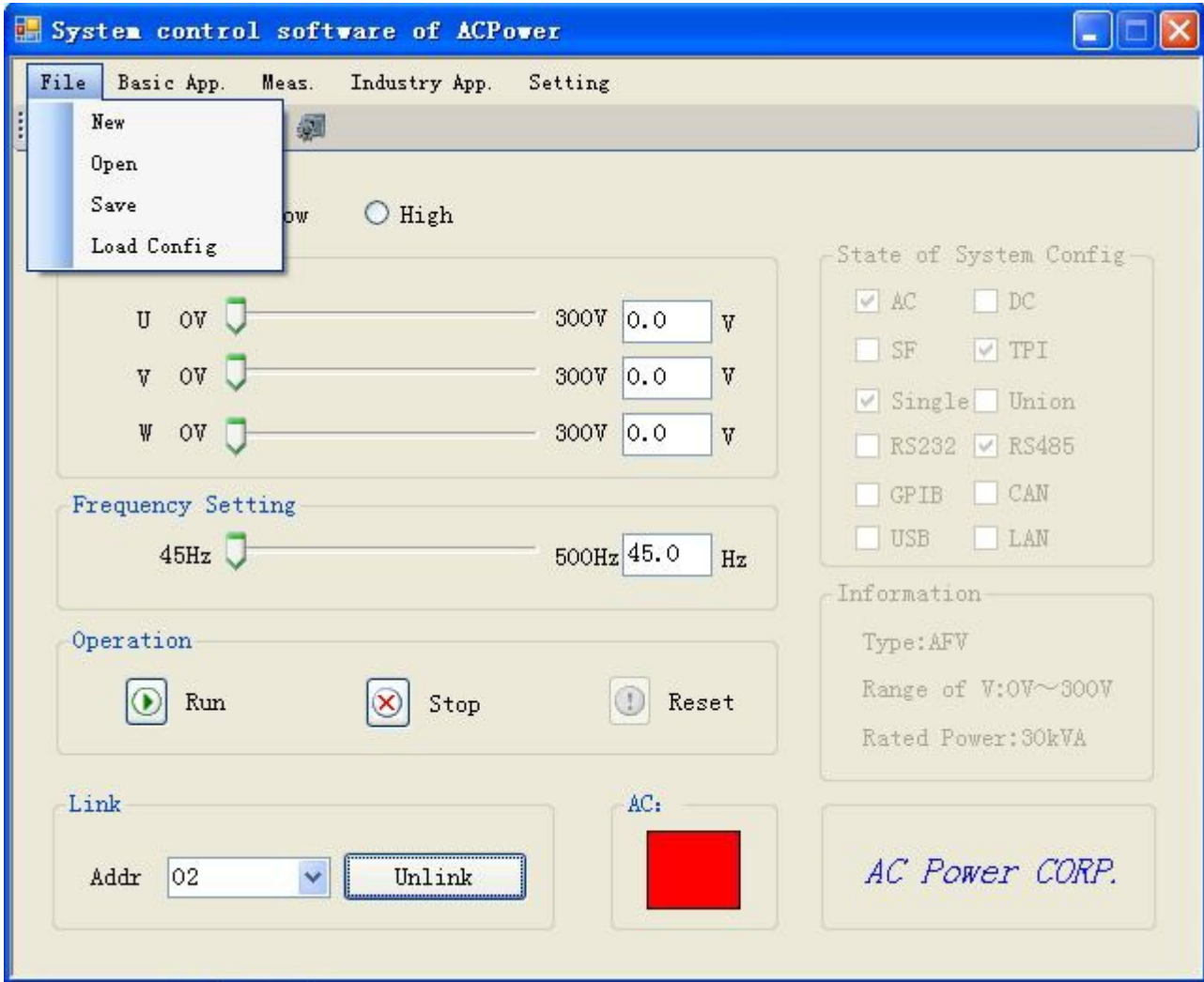

Fig. 5-20 File menu

The drop-down file menu is shown in the system control screen in the above figure.

- **【New】** : Select to create a new system data file.
- **【Open】** : Choose to open the existing system data file.
- **【Save】** : Select to save the existing user settings in the current system data file.
- **【Load Config】** : Select to import the system configuration files of the software.

Note : The default system data file of the software is *syssoft.ini*. This file keeps the system settings, the application function data set by the users, and other information. It preserves the latest operational data set by the users for when the software runs the next time.

5.5.4 System setting

1) Language setting

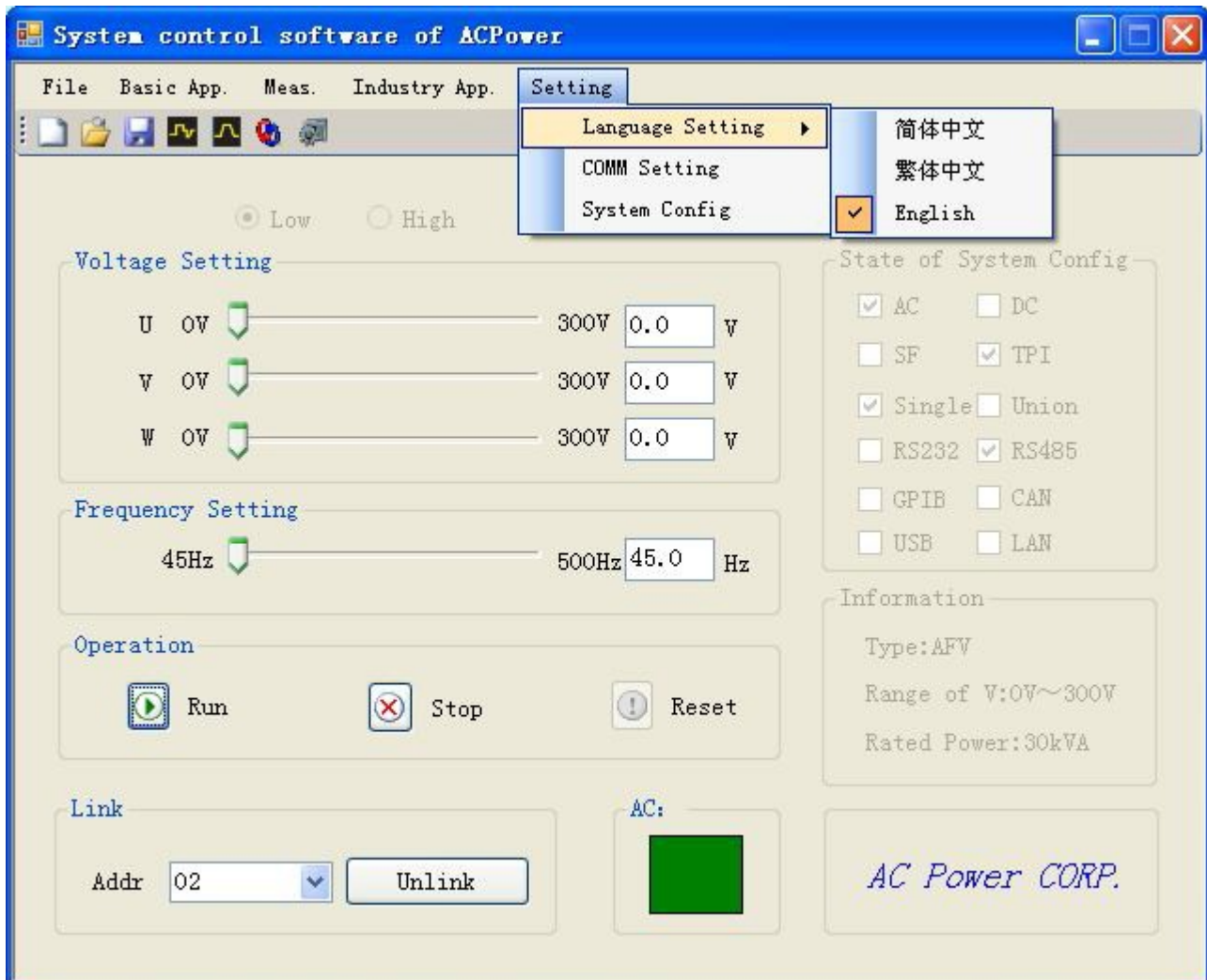

Fig. 5-21 Language setting

Users can select any of three languages in Language Setting, including Simplified Chinese, Traditional Chinese and English. After selecting the language all of the text on all of the interfaces will switch to the selected language.

2) Communication setting

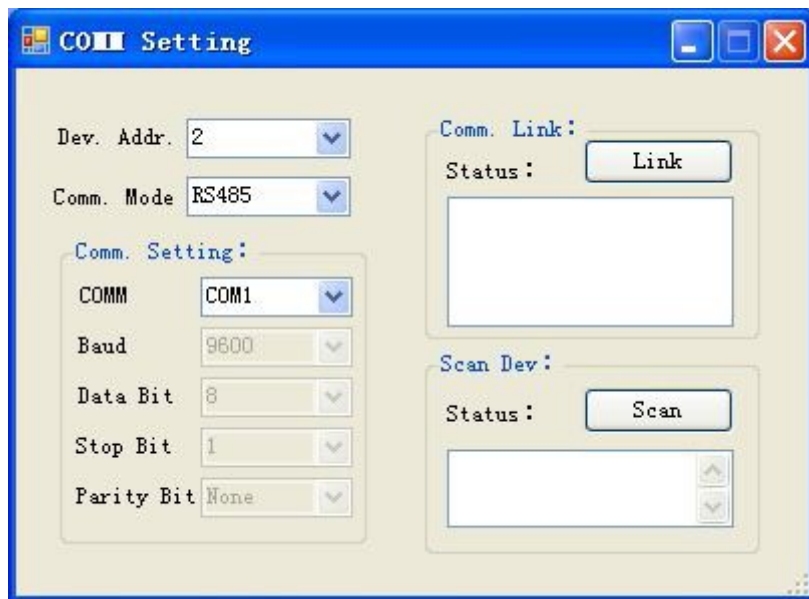

Fig. 5-22 Communication setting

- **【Dev. Addr.】** --Instrument address: For the contact address of the power-supply device; When the power supply model is configured to AFV, the address of the instrument defaults to 2.
- **【Comm. Mode】** --Communication method: There are three optional communication methods. These are RS232, RS485 and GPIB.
- When selecting GPIB as the communication method, the setting group of serial port parameters will be in a grey and inoperable state.
- **【Comm. Link】** -- Connection establishment: You can select this to establish a communication connection with the power supply after having selected communication method and communication parameter. The edit box below this button will display the connection state.
- **【Scan Dev】** --Scan device: This function can be used to scan the device on the communication link if you do not know the address of the currently-connected power-supply device. The list box below the Scan button will display the results.

3) On the System Control - Setting drop-down menu - select the [System Config] option to proceed to the interface shown below in Figure 5-23:

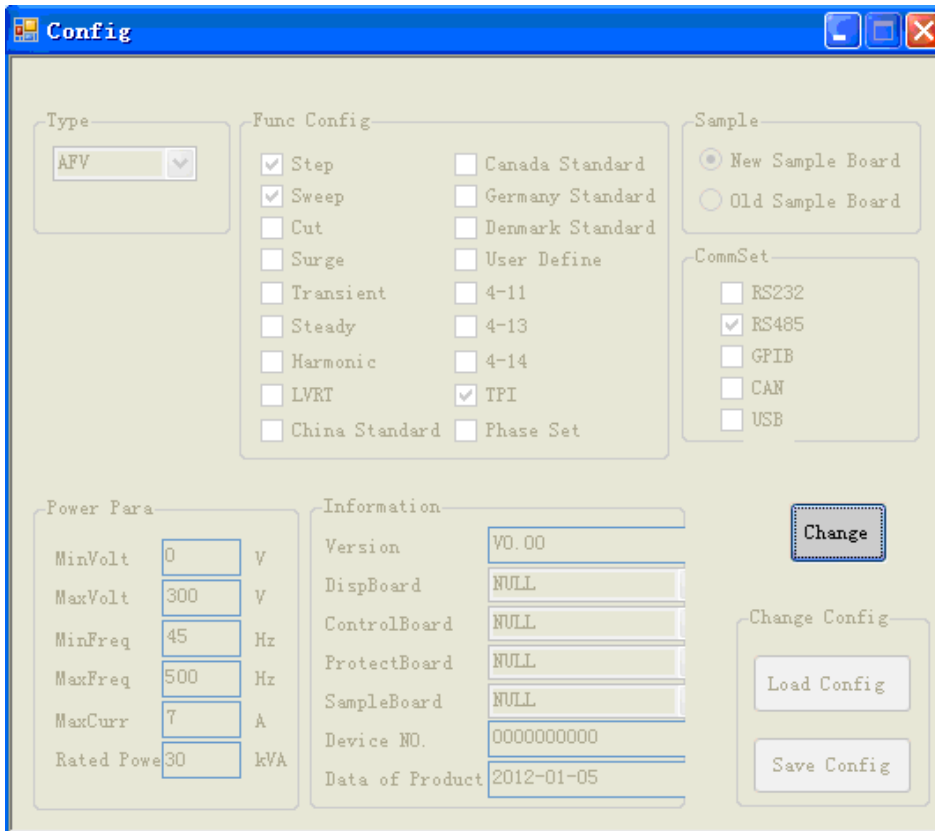

Fig. 5-23 system configuration interface in remote control

On the system configuration interface, the user can view the product model, applications configuration, communication interface configuration, parameter settings and power supply hardware and software version information.

NOTE: The system configuration for the user to view under normal circumstances, can not be modified. If you need to modify the system configuration, please contact Intepro Systems customer service staff.

NOTE: After the user is successfully connected via remote control, the local control interface is locked; press [local] to unlock.

Chapter VI Repair and Maintenance

Ambient temperature, humidity, dust, vibration, aging and wear of components within the equipment, and other reasons all affect the equipment and could potentially cause faults to occur. Therefore, it is necessary to conduct daily and regular repair and maintenance of the equipment.



Only trained, authorized and qualified professionals can maintain the equipment

6.1 Daily repair and maintenance

The installation environment and the operating environment of the equipment must meet the provisions of this user manual. During normal use, daily maintenance work should be done to ensure a good operating environment; daily operating data, parameter setting data, parameter change record and other data should be recorded to establish and improve equipment application files.

Through daily maintenance and inspection, various abnormal conditions can be detected early. The causes of the abnormalities and the hidden dangers of faults can then be eliminated as soon as possible. This allows the equipment to operate normally and its service life can be extended. Please refer to Table 6-1 for daily inspection items.

Table 6-1 Daily inspection description table

| Inspection object | Main points of inspection | | | Evaluation criteria |
|-----------------------|--|---------|--|--|
| | Inspection contents | Cycle | Inspection means | |
| Operating environment | (1)Temperature and humidity (2)Dust, moisture and leak (3) Gas | Anytime | (1) Thermometer and hygrometer (2) Observation (3)Observation and sniffing | (1)The ambient temperature should be lower than 40°C, or the equipment will operate with reduced capacity. Humidity meets environmental requirements. (2) There are no dust bunnies, water leak traces or condensation. (3) There are no abnormal colors or odors. |
| Equipment | (1) Vibration (2)Cooling and heating (3) Noise | Anytime | (1)Comprehensive observation (2) Thermometer (3) Listening | (1)The equipment operates smoothly and reliably without vibration. (2) The fan operates normally, and wind speed as well as wind volume is normal. Detection is done in the wind hole at the top of the chassis. (3) There is no abnormal noise. |

| | | | | |
|----------------------------|--|---------|--|--|
| Operating state parameters | (1)Power input voltage (2)Variable frequency power output voltage (3)Variable frequency power output current (4)Internal temperature | Anytime | (1) Voltmeter (2) Rectifier-type voltmeter (3) Ammeter (4) Digimite | (1) Specifications are met. (2) Specifications are met. (3) Specifications are met. (4) Temperature rise is lower than 40°C |
|----------------------------|--|---------|--|--|

6.2 Regular maintenance

Depending on the application environment, users can conduct a regular inspection of the equipment once every three to six months.

General inspection contents:

Clean air intake filter regularly.

Note: When removing or installing the filter, there is no need to open the front door. For access only the suction canal need be removed to allow the filter to be taken out.

Chapter VII Troubleshooting and Solutions

Before seeking service, users should first inspect the unit and record fault details according to information in this section. If service is required, please contact Intepro Systems.

| Fault code | Fault type | Possible causes of faults | Solutions |
|------------|----------------------------------|--------------------------------------|---------------------------------|
| Err-01 | U-phase IGBT1 over current fault | U-phase IGBT is damaged | Check and replace IGBT |
| Err-02 | U-phase IGBT2 over current fault | U-phase IGBT is damaged | Check and replace IGBT |
| Err-03 | U-phase IGBT3 over current fault | U-phase IGBT is damaged | Check and replace IGBT |
| Err-04 | U-phase IGBT4 over current fault | U-phase IGBT is damaged | Check and replace IGBT |
| Err-05 | V-phase IGBT1 over current fault | V-phase IGBT is damaged | Check and replace IGBT |
| Err-06 | V-phase IGBT2 over current fault | V-phase IGBT is damaged | Check and replace IGBT |
| Err-07 | V-phase IGBT3 over current fault | V-phase IGBT is damaged | Check and replace IGBT |
| Err-08 | V-phase IGBT4 over current fault | V-phase IGBT is damaged | Check and replace IGBT |
| Err-09 | W-phase IGBT1 over current fault | W-phase IGBT is damaged | Check and replace IGBT |
| Err-10 | W-phase IGBT2 over current fault | W-phase IGBT is damaged | Check and replace IGBT |
| Err-11 | W-phase IGBT3 over current fault | W-phase IGBT is damaged | Check and replace IGBT |
| Err-12 | W-phase IGBT4 over current fault | W-phase IGBT is damaged | Check and replace IGBT |
| Err-13 | Radiator over-temperature | The fan works abnormally | Check the fan |
| Err-14 | Transformer over-temperature | The fan works abnormally | Check the fan |
| Err-15 | Emergency stop button | The emergency stop button is presses | Check the emergency stop button |
| Err-16 | Fuse 1 is broken | The fuse blows out | Check and replace the fuse |
| Err-17 | Fuse 2 is broken | The fuse blows out | Check and replace the fuse |
| Err-18 | Fuse 3 is broken | The fuse blows out | Check and replace the fuse |
| Err-19 | IGBT over-temperature 1 | The fan works abnormally | Check the fan |
| Err-20 | IGBT over-temperature 2 | The fan works abnormally | Check the fan |
| Err-21 | Input under voltage fault | The input voltage is too low | Check the input voltage |
| Err-22 | Input over voltage fault | The output voltage is too high | Check the input voltage |
| Err-23 | DC voltage is too low | The input voltage is too low | Check the input voltage |
| Err-24 | DC voltage is too high | The output voltage is too high | Check the input voltage |
| Err-25 | U overload | U-phase overload | Check the load |
| Err-26 | V overload | V-phase overload | Check the load |
| Err-27 | W overload | W-phase overload | Check the load |
| Err-28 | Output under voltage fault | The output voltage is too low | Check the output voltage |
| Err-29 | Output over voltage fault | The output voltage is too high | Check the output voltage |

Table 7-1 Alarm contents and solutions

Chapter VIII After-Sales Service

Intepro Systems provides a full range of technical support to customers. Customers are encouraged to contact our branch office or our technical personnel when you have purchased our product.

For the details of warranty, please refer to the terms of warranty. We provide paid customization service packages at different levels, including fast response, preventive maintenance, and warranty renewal service. Please contact the local service centers of our company.

- Service Telephone
USA: +1.714.953.2686
UK/Europe: +44.1251.875600
Asia: +86.755.86500020
- On-line technical service: www.InteproATE.com
- Intepro Systems America, LP
14712-A Franklin Avenue
Tustin, CA 92780
USA
Tel: +1.714.953.2686
Fax: +1.714.673.6567



**Quality
Service
Innovation**

Warranty Card

Dear _____,

Thanks for your support and patronage. This card is to ensure that in case the grid simulators you have purchased (model: _____, serial number: _____) fail in normal conditions of use within a year because of the process error or component deterioration, Intepro Systems, LP. will have responsibility to provide after-sales service for free.

Please note:

The machine is required to be installed and used properly. Do not modify the structure, circuit or component.

1. If the machine has faults, please call us or pack the machine properly and indicate the faults before sending back to our company. We will serve you as soon as possible.
2. If the warranty period expires, and the customer keeps the card, we will charge a reasonable fee after the completion of repair.

Attn: _____

Date: _____

