

---

ANFC Series  
AC Power Supply  
User Manual (V1.0)

---

## Appearance of ANFC Series



---

## Notice

**Any change to this manual will not be informed additionally.**

**Read this manual carefully before using this instrument. Keep the manual near the instrument for convenient reference. Keep this manual accompanying this instrument during delivery.**

**Error may occur for this manual. For any errors or questions, contact Ainuo Instrument Company Service Center or the agent in time. We will not be responsible for any direct, indirect, accident or consequential damage caused by errors in this manual or using of this manual.**

**Copyright: Ainuo Instrument Company. Copying, printing or modification to this manual is forbidden without permission.**

## Warrantee















- 1, We (Ainuo Instrument Company) guarantee that all products produced by us have passed strict quality inspection. The warrantee period for our products is twelve (12) months. Any defect or faults occurred within this period due to manufacturing will be repaired free of charge.**
- 2, For any faults caused by modification to the circuits or function by the user without permission or after the warrantee period, we will charge the cost accordingly. For failure and damage caused by force majeure, we will not provide free warranty service.**

## Safety Instructions

**The safety instructions in this manual must be followed during operation, maintenance and repair of the power supplies. Failure to follow these safety precautions, the manufacturer will not be responsible for any operation failing to follow the safety instructions by the user.**

## Safety Marks

### 1, Electric Symbols, Safety Marks and Warning Marks

Symbol	Description		Symbol	Description
	<b>AC</b>	Alternating Current		Forbidden
	<b>DC</b>	Direct Current		Power ON
	<b>AC/DC</b>	AC or DC		Power OFF
<b>N</b>	<b>N</b>	Neutral conductor		Power ON/Off (Two positions).
	<b>PE</b>	Protective Conductor		
	Earth			High Temp.: The Temp. is higher than the limit for human body. Do not touch to avoid injury.
	Precautions: Refer to the instructions in the manual to avoid damage to the device or personnel injury.			Electricity shock!
	Risks! Fail to follow the instruction will cause personal injury. Do not operate the instrument before understanding the instruction.		 <b>Caution</b>	Risks! Fail to follow the instruction may cause death or injury. This mark prompts for procedures, practices and conditions etc.

---

## 2, Safety Instructions

**Pay attention to the precautions in this manual during operation or maintenance.**

**We will not be responsible for any personnel injury or damage to the machine due to failing to observing these precautions.**



Read this manual carefully before using this equipment and keep it well.



Do not use this product for purpose other than those described in this manual.

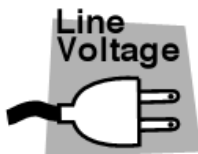

Check the power ratings before power ON. Make sure the switch is at OFF position.



Earth: Ground the device firmly before power on.



Precautions (earth): Never disconnect the internal/external earth wires or earth terminals to avoid personnel injury due to shock.



Fuse: Only use fuse with required rated current/voltage or special one (normal fuse, time delay etc). Never use fuse of other size or short-connect the fuse to avoid shock or fire.



Do not remove the house.  
The operator shall not dismantle the case. Only qualified engineers can change or adjust the parts.



Never operate the device in explosive or corrosive environment  
Never operate the device in flammable gas or corrosive environment



- Turn off the power before handling the unit, and disconnect all wires.
- This unit weights 20Kg or more, which can be found in the manual.

Handle the unit by two persons or more.

- Be careful during handling this unit to avoid falling.
- Deliver this product accompanied with this manual.



- Check if the AC power supply is consistent with the size of the fuse. Check the power line. Disconnect the power line or turn off the power switch before inspection.

Stop operation immediately in case of any abnormalities or faults. Disconnect the power line or turn off the power switch in the distribution box. Do not use it before it is repaired.

- Use cables with high overcurrent capability for output or load lines.
- Use cables with high overcurrent capability for output or load lines.

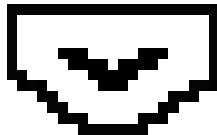

Keep water or metal objects out of this product.



### Caution

*Any damage to the instrument due to improper power input is not covered within the warranty period.*



### Warning

*After the voltage/current is set and the output starts, high voltage exists at the output terminal. Never touch it to avoid personnel injury or even death.*

---

# Table of Contents

<b>CHAPTER 1 OVERVIEW .....</b>	<b>1</b>
1.1 INTRODUCTION.....	1
1.2 FUNCTIONS AND FEATURES .....	1
1.2.1 Features.....	1
1.2.2 Panels.....	3
1.2.3 Remote Programmable Control.....	3
1.3 SPECIFICATION .....	3
1.4 PANELS.....	8
1.4.1 Front panel of 3-phase power supply.....	8
1.4.2 Front panel of single-phase power supply .....	10
1.5 APPLICABLE STANDARDS .....	11
<b>CHAPTER 2 UNPACKING AND INSTALLATION .....</b>	<b>12</b>
2.1 UNPACKING INSPECTION .....	12
2.1.1 Inspection Prior to Unpacking.....	12
2.1.2 Unpacking .....	12
2.2 OPERATING ENVIRONMENT .....	12
2.2.1 General.....	12
2.3 INPUT WIRING .....	13
2.4 OUTPUT WIRING.....	14
2.4.1 3-phase Output Wiring .....	14
2.4.2 Single-phase Output Wiring .....	14
2.5 SECTION OF CABLE .....	14
<b>CHAPTER 3 OPERATION.....</b>	<b>15</b>
3.1 PREPARATION AND INSPECTION .....	15
3.2 START.....	16
3.3 LIST OF OPERATIONS .....	18
3.4 SHUTDOWN .....	23
<b>CHAPTER 4 OPERATIONS ON THE PANEL OF 3-PHASE POWER SUPPLY .....</b>	<b>24</b>
4.1 STANDBY.....	24
4.1.1 Choose shortcuts .....	24
4.1.2 Shortcuts.....	24
4.1.3 Switch to other screen .....	25
4.2 OUTPUT SETTING .....	25
4.2.1 Change Output Voltage Setting .....	25
4.2.2 Change Output Frequency Setting .....	26
4.2.3 Change Increase Setting.....	26
4.2.4 Change Decrease Setting .....	26
4.2.5 Shortcuts.....	26
4.2.6 Exit Output Setting screen.....	27

---

4.3 START SCREEN .....	27
4.3.1 Online Voltage Adjustment .....	27
4.3.2 Online Frequency Adjustment .....	28
4.3.3 Shortcuts.....	28
4.3.4 STOP output .....	28
4.4 SYSTEM SETTING .....	28
4.4.1 OCP current Adjustment .....	29
4.4.2 Start Ramp Adjustment.....	29
4.4.3 Line Impedance Adjustment .....	29
4.4.4 Key tone Adjustment.....	29
4.4.5 Address Adjustment .....	30
4.4.6 Baudrate Adjustment.....	30
4.4.7 Exit System Setting .....	30
4.5 ALARM SCREEN .....	30
4.5.1 Eliminating of Alarm.....	31
4.6 ONLINE MONITORING.....	31
4.7 OPERATING DATA RECORDER .....	31
4.7.1 Alarm Operating Data Recorder.....	32
4.7.2 Running Operating Data Recorder .....	32
4.7.3 Restore Default Settings .....	32
<b>CHAPTER 5 OPERATIONS ON THE PANEL OF SINGLE-PHASE POWER SUPPLY .....</b>	<b>33</b>
5.1 STANDBY.....	33
5.1.1 Choose shortcuts .....	33
5.1.2 Shortcuts.....	33
5.1.3 Switch to other screen .....	34
5.2 OUTPUT SETTING .....	34
5.2.1 Change Output Voltage Setting .....	34
5.2.2 Change Output Frequency Setting .....	34
5.2.3 Change Increase Setting.....	35
5.2.4 Change Decrease Setting .....	35
5.2.5 Shortcuts.....	35
5.2.6 Exit Output Setting screen.....	35
5.3 START SCREEN.....	35
5.3.1 Online Voltage Adjustment .....	36
5.3.2 Online Frequency Adjustment .....	36
5.3.3 Shortcuts.....	36
5.3.4 STOP output .....	37
5.4 SYSTEM SETTING .....	37
5.4.1 OCP current Adjustment .....	37
5.4.2 Start Ramp Adjustment.....	37
5.4.3 Line Impedance Adjustment .....	37
5.4.4 Key tone Adjustment.....	38
5.4.5 Address Adjustment .....	38
5.4.6 Baudrate Adjustment.....	38

---

---

5.4.7 Exit System Setting .....	38
5.5 ALARM SCREEN .....	38
5.5.1 Eliminating of Alarm.....	39
5.6 ONLINE MONITORING.....	39
5.7 OPERATING DATA RECORDER .....	40
5.7.1 Alarm Operating Data Recorder.....	40
5.7.2 Running Operating Data Recorder .....	41
5.7.3 Restore Default Settings .....	41
<b>CHAPTER 6 INSPECTION AND MAINTENANCE .....</b>	<b>42</b>
6.1 MAINTENANCE AND CARE.....	42
6.1.1 Daily Maintenance.....	42
6.1.2 Maintenance.....	42
6.1.3 Repair by Users.....	42
6.1.4 Maintenance and Care for Long-term Storage.....	43
6.2 TROUBLESHOOTING.....	43
6.3 STORAGE AND TRANSPORTATION.....	44
6.3.1 Storage .....	44
6.3.2 Transportation.....	45
<b>CHAPTER 7 REMOTE COMMUNICATION/CONTROL .....</b>	<b>46</b>
7.1 PROTOCOL.....	46
7.1.1 Handshake Protocol.....	46
7.1.2 Protocol Agreement.....	46
7.1.3 Receive Protocol and Frame Format.....	47
7.1.4 Send Protocol .....	47
7.1.5 List of Commands.....	48
7.1.6 Commands.....	49
7.2 INTERFACES.....	53
7.2.1 RS232/RS485.....	53
7.2.2 GPIB.....	53
7.2.3 Ethernet.....	54
7.3 ANALOG CONTROL.....	55
7.3.1 Analog Control Panels .....	55
7.3.2 Analog Control screen 下的 panel operation.....	55
7.3.3 Pins of Analog Control Socket .....	55
7.3.4 Control and Detection of Analog Control Interface .....	57
7.4 SOFTWARE (OPTIONAL) .....	58
<b>ANNEX I TABLE OF ALARM CODES .....</b>	<b>59</b>



## Chapter 1 Overview

### Guide:

- Introduction
- Functions and Features
- Specification
- Panels
- Applicable Standard

### 1.1 Introduction

This Ainuo AC power supply can supply voltage for power grids all over the world, applicable to manufactures of export electrics, laboratories, national defense and other industries. This power supply adopts digital technology and intelligent IGBT output, featuring excellent dynamic characteristics, load adaptability, high efficiency, simple operation and advanced techniques.

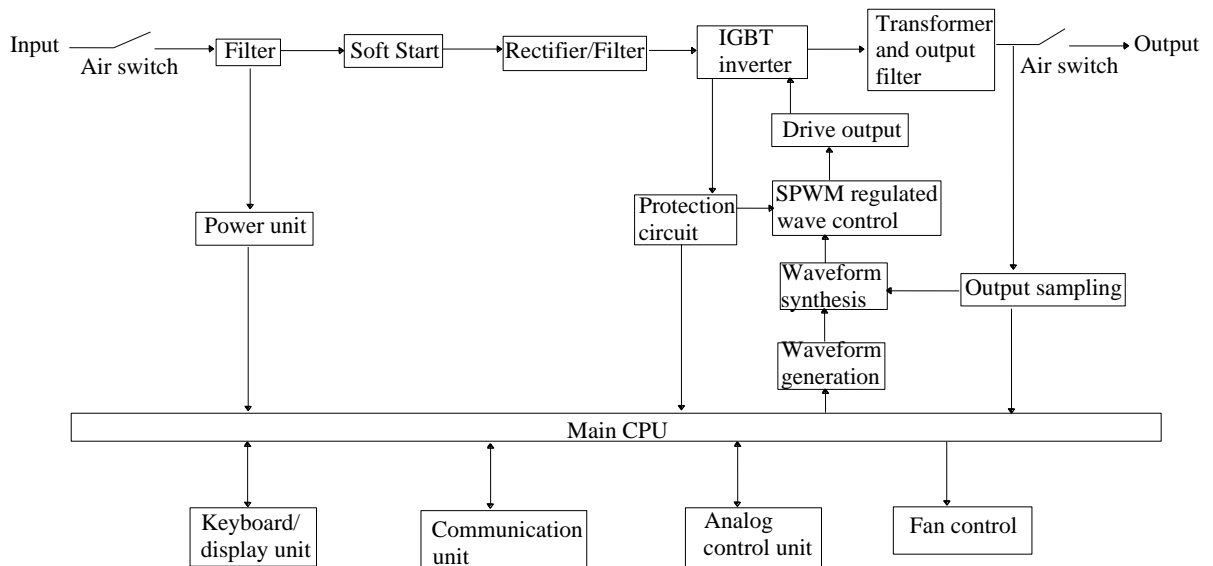

Figure 1-1 Block Diagram

### 1.2 Functions and Features

#### 1.2.1 Features

##### 1) Stable voltage and frequency output

Output voltage: 1.0~300.0V, output frequency: 45.0~65.0Hz, 100Hz, 120Hz, 200Hz, 240Hz.

After setting of voltage/frequency, the output voltage stability is better than 0.3%, and the

frequency stability is better than 0.02%.

## 2) Online adjustment of output voltage and frequency

In case of output of power supply, Press *Set* to select the voltage or frequency to be adjusted. Press Increase/Decrease and turn the knob to adjust the output.

You can also press  $+\Delta U$  or  $-\Delta U$  to increase/decrease the output voltage quickly by percentage of the starting output, which is pre-set in the Standby screen.

## 3) Output mode and phase voltage (3-phase output only)

Output modes: 3-phase output, U-phase, V-phase or W-phase separate output, which can be switched quickly via the output mode key for convenient operation by the user in various application.

In 3-phase output mode, the user can set line/phase voltage and display via shortcuts.

## 4) Safe and reliable self-protection

Comprehensive self-test: real-time detection on IGBT, transformers and other key components (e.g. short circuit/overcurrent/overheating protection), as well as I/Os (e.g. overvoltage/undervoltage/phase failure protection).

## 5) Start ramp and impact capacity up to three times of rated current

For motors, rectifiers or capacitors, as the power supply outputs high voltage directly, impact current of several or dozen times of normal current will occur, enabling protection of the power supply. To ensure normal start of such load and Start Ramp, keep the output voltage rise gradually, thus ensure safe start.

For motors, rectifiers or capacitors, the power supply can has impact current up to three times of rated current, that is, it can output three times of rated current lasting for 2 seconds while run normally.

## 6) Output range

The output voltage can be divided into High (higher than 150.0V) and Low (equal to or lower than 150.0V). The maximum output current at High is twice of that of Low voltage, ensuring proper output power for High/Low output.

The High output can be locked via the key Auto/High.

## 7) Shortcuts and quick operation

7 groups of shortcuts for storage of common parameters for fast call by the user.

Via the shortcuts on the panel, the customers can quickly switch to common voltage settings (120/220V) and frequency settings (50/60/100/120/200/240Hz).

## 8) Line resistance compensation

High output current will cause voltage drop along the output line, so that the voltage on the load will reduce. With the line resistance compensation, the actual line voltage can be compensated by the set compensation parameters.

### 9) Lock

After setting and no change will be made, click Lock to lock the keyboard so as to prevent any mis-operation. As the keyboard input is locked, click Lock to enable. In case there is no operation of the power supply for more than 5 minutes, the keyboard input will be automatically locked.

As the keyboard input is locked, only the key STOP is valid except for the key Lock, you may click STOP to stop the output under abnormal conditions.

### 10) Operating Data Recorder

Record the latest 20 operations and alarms, so that the user can review the running/alarm state of the power supply for maintenance.

## 1.2.2 Panels

Click keys to set and control output modes and voltage/frequency, and the output state is shown on the LCD display. Main features:

- Start/STOP output
- Set output mode (3-phase output only)
- Set output voltage, frequency, percentage of voltage
- Set communication parameters (address and baudrate), Line Impedance, Start Ramp Time
- Display of power supply state: Standby/output/Alarm (Alarm Code) etc.
- Display of output voltage, frequency, current, power
- Display of input voltage, internal temperature measurement
- Display of measurement of Running Operating Data Recorder and Alarm Operating Data Recorder

## 1.2.3 Remote Programmable Control

Optional RS232/RS485/GPIB/Ethernet, analog control and other remote communication/control modes are set for remote control of power supplies.

## 1.3 Specification

This ANFC series AC power supplies are divided into two series: "three-phase" and "single-phase" according to the output mode. Each series consists of multi models according to the power. The specific output specifications are shown in Table 1-1 and Table 1-2.

**Table 1-1 Specification of 3-phase output power supplies**

Model /Parameters		ANFC015T(F)	ANFC030T(F)	ANFC045T(F)	ANFC060T(F)	ANFC090T(F)	ANFC100T(F)
Input		3-phase 4-line, AC: 380V ±57V, 50/60Hz ±3Hz					
Output capacity		15kVA	30kVA	45kVA	60 kVA	90 kVA	100kVA
Output frequency		45.0~65.0Hz, 100Hz, 120Hz, 200Hz, 240Hz					
Frequency stability		≤0.02%					
Output voltage		3-phase 4-line, 1.0~300.0V					
Output rated current	110V	45.4A	90.9A	136.3A	181.8A	272.7A	303.0 A
	220V	22.7A	45.4A	68.2A	90.9A	136.3A	151.5A
Dimension W*H*D (mm)		600*1130*1018		700*1330*1218			800*1730*1418
Weight (KG)		235	270	400	480	540	880

Model /Parameters		ANFC120T(F)	ANFC150T(F)	ANFC180T(F)	ANFC200T(F)	ANFC240T(F)	ANFC250T(F)
Input		3-phase 4-line, AC: 380V ±57V, 50/60Hz ±3Hz					
Output capacity		120kVA	150kVA	180kVA	200kVA	240kVA	250kVA
Output frequency		45.0~65.0Hz, 100Hz, 120Hz, 200Hz, 240Hz					
Frequency stability		≤0.02%					
Output voltage		3-phase 4-line, 1.0~300.0V					
Output rated current	110V	363.6A	454.5A	545.4A	606.0A	727.2A	757.6
	220V	181.8A	227.2A	272.7A	303.0A	363.6A	378.8A
Dimension W*H*D (mm)		800*1730*1418					
Weight (KG)		880	1060	1100	1190	1240	1240

**Table 1-2 Specification of single-phase output power supplies**

Model /Parameters	ANFC015S (F)	ANFC020S (F)	ANFC030S (F)	ANFC045S (F)	ANFC060S (F)	ANFC090S (F)	ANFC100S (F)	ANFC120S (F)
Output capacity	3-phase 4-line, AC: 380V ±57V, 50/60Hz ±3Hz							
Output frequency	15kVA	20kVA	30kVA	45kVA	60 kVA	90 kVA	100kVA	120 kVA
Frequency stability	45.0~65.0Hz, 100Hz, 120Hz, 200Hz, 240Hz							
Output voltage	≤0.02%							
Output capacity	single-phase, 1.0~300.0V							

Output rated current	110V	136.4A	181.8A	272.7A	409.1A	545.4A	818.2A	909.0A	1090.9A	
	220V	68.2A	90.9A	136.3A	204.5A	272.7A	409.1A	454.5A	545.4A	
Dimension W*H*D (mm)		600*1130*1018			700*1330*1218			800*1730*1418		
Weight (KG)		175	190	250	370	500	560	860	900	

Table 1-3 Specification of common

Control /measurement accuracy	Voltage	Resolution: 0.1V
	Phase voltage	Accuracy: 0.2%×reading +0.2%×full scale (45Hz~65Hz, 110/220V±10%); 0.4%×reading +0.4%×full scale (other ranges)
	Line voltage	Accuracy: 0.25%×reading +0.25%×full scale (45Hz~65Hz, 190.5/381.0V±10%); 0.5%×reading +0.5%×full scale (other ranges)
	Current	Resolution: 0.1A/1A Accuracy: 0.3%×display +0.3%×rated output
	Frequency	Resolution: 0.1Hz Accuracy: 0.05%
	Power <sup>Note 1</sup>	Resolution: 0.1kW/0.01kW/0.001kW Accuracy: 0.45%×reading +0.45%×full scale (45Hz - 65Hz) 0.8%×reading + 0.8%×full scale (other range)
Source voltage effect		≤1%
Load effect		≤1%
Output voltage distortion		Linear load: THD<1% (110V±10%, 220V±10%, frequency: 45-65Hz); THD<3% (other ranges <sup>Note 2</sup> )
Transient total recovery time		20ms
3-phase phase difference		120°±2° (3-phase output power supplies)
3-phase voltage unbalance factor		≤1% (3-phase output power supplies)
Phase voltage crest factor		1.41±0.1
Voltage modulation amplitude		≤3V
Overload alarm <sup>Note 3</sup>		105%< output ≤110%: Cut off the output within 15S; 110%< output ≤200%: Cut off the output within 5S 200%< output ≤300%: Cut off the output within 2S; 300%< output: Cut off the output immediately
Protection		IGBT overheating, IGBT overcurrent, transformer overheating, input overvoltage/undervoltage, output overvoltage/undervoltage, output phase failure, output overcurrent, output overload
Line resistance compensation		0.000~0.500 Ω
Start ramp time		0.0~99.9 Sec.
Efficiency		>86%
Programmable memory		7 groups of memory
Online regulation		Online regulation of output voltage, 45.0~65.0Hz output frequency.
Remote communication/control ports		Port: RS232 (standard), RS485 (optional), GPIB (optional), Ethernet (optional) Control port: analog control port (optional)
Working environment		Temp.: 0~40℃ Relative Humidity: 20~90%RH

Note 1: The power measurement accuracy is under condition: PF≥0.9.

Note 2: The output voltage distortion measurement: 10V-300V.

**Note 3: The overload capacity is measured under ambient temperature 10~40°C and resistive load; the alarm is triggered as either output current or power meets the condition.**



**Note:** The above specifications are subject to change without notice.

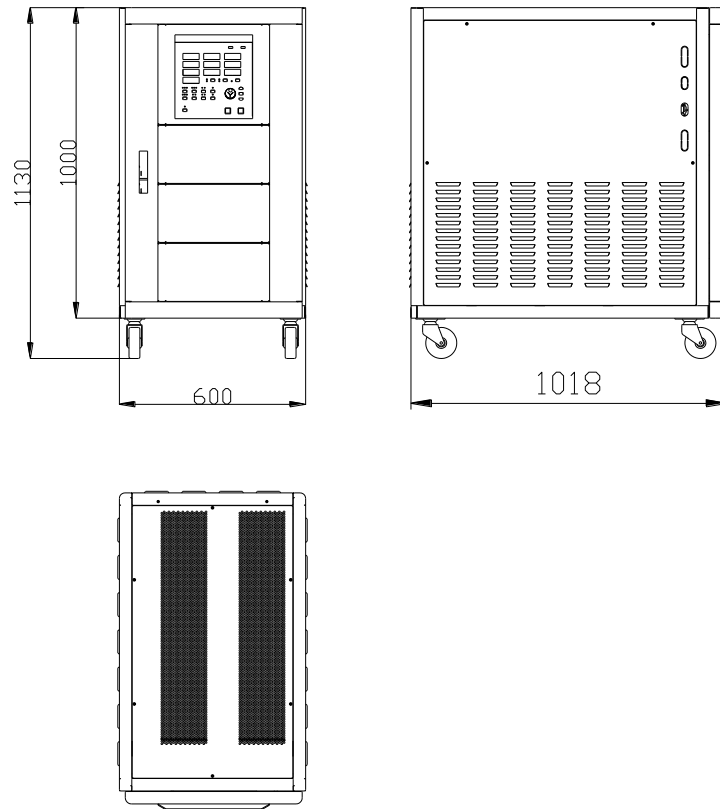

Figure 1-2 Dimension of 15-30kVA power supply

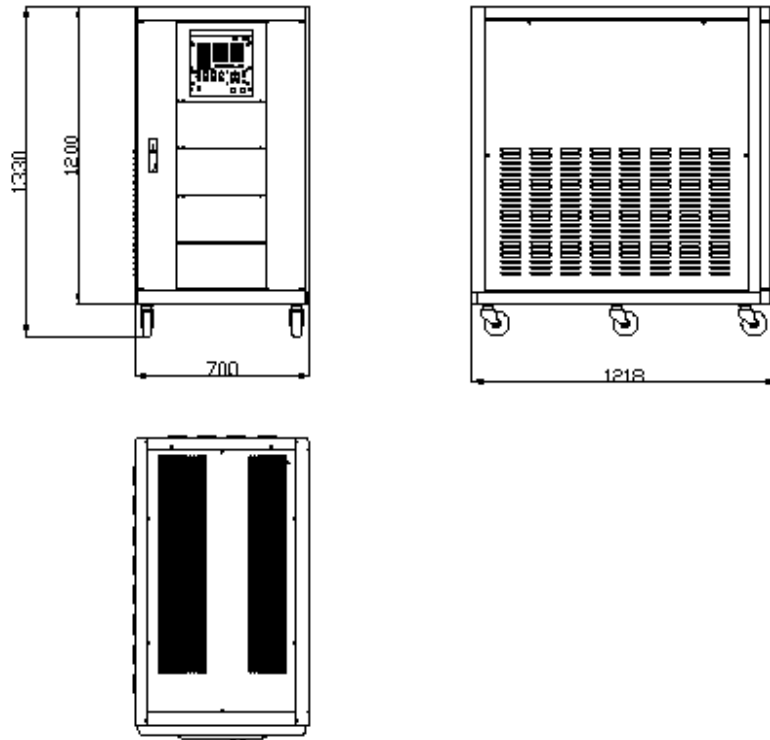

Figure 1-3 Dimension of 45-90kVA power supply

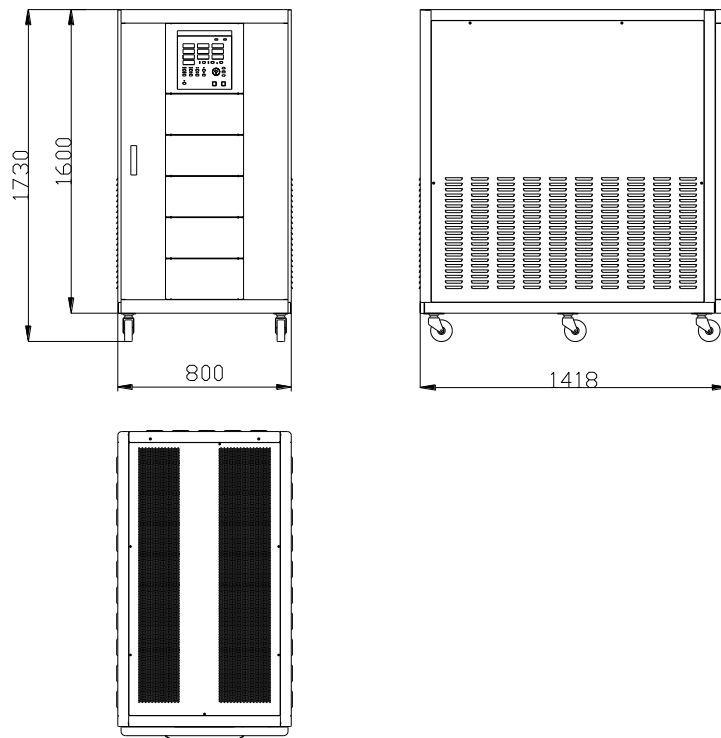

Figure 1-4 Dimension of 100-250kVA power supply

## 1.4 Panels

### 1.4.1 Front panel of 3-phase power supply

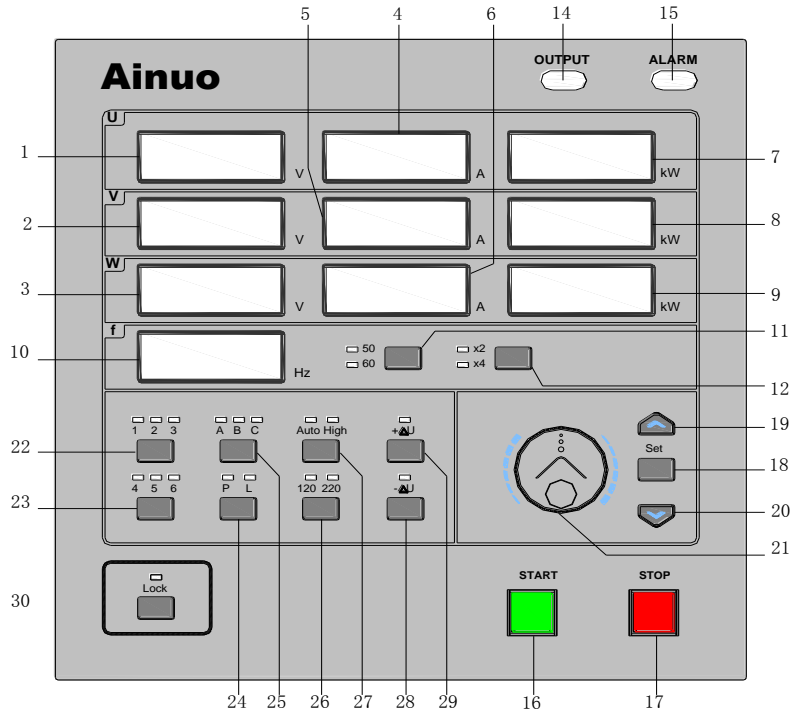



Figure 1-5 Panel of 3-phase power supply

Table 1-4 Panel of ANFC 3-phase output power supply

No.	Name	Function
1	U-phase voltage display	Display actual U-phase output voltage in Running screen; display pre-set voltage in Standby, Pre-set Voltage and Online Adjustment state.
2	V-phase voltage display	Display actual V-phase output voltage in Running screen; display pre-set voltage in Standby, Pre-set Voltage and Online Adjustment state.
3	W-phase voltage display	Display actual W-phase output voltage in Running screen; display pre-set voltage in Standby, Pre-set Voltage and Online Adjustment state.
4	U-phase current display	Display actual U-phase output current in Running screen; display Fault No. in Fault state; display 0 in Standby screen.
5	V-phase current display	Display actual V-phase output current in Running screen; display Fault No. in Fault state; display 0 in Standby screen.
6	W-phase current display	Display actual W-phase output current in Running screen; display Fault No. in Fault state; display 0 in other states.
7	U-phase power display	Display actual U-phase output power in Running screen.
8	V-phase power display	Display actual V-phase output power in Running screen.
9	W-phase power display	Display actual W-phase output power in Running screen.

## Chapter 1 Overview **Ainuo**<sup>®</sup>

10	Frequency display	Display pre-set frequency in Standby and Pre-set state; display actual output frequency in 3-phase and single-phase Running screen.
11	50 60	Combined operation in Standby screen. Quick switching between 50, 60, 100, 120, 200, 240Hz.
12	×2 ×4	
14	OUTPUT LED	Green. On in Running screen.
15	ALARM LED	Red. Flashing in Alarm screen.
16	START	OUTPUT LED is ON as the output starts.
17	STOP	Click STOP in Running or Pre-set state to enter the Standby screen; or eliminate sound & light alarm in Alarm screen.
18	Set	Click the key in Standby screen to choose pre-set voltage, frequency, voltage increase/decrease. Press the key and hold for 3S in Standby screen to set address, baudrate, Line Impedance, Start Ramp Time. Click the key in Running screen to adjust voltage or frequency online.
19		Increase the corresponding parameter.
20		Decrease the corresponding parameter.
21	Knob	Turn the knob clockwise to increase; turn it counterclockwise to decrease.
22	123	Quick switch between shortcuts 0, 1, 2, 3 in Standby screen.
23	456	Quick switch between shortcuts 0, 4, 5, 6 in Standby screen.
24	PL	Switch phase/line voltage display/setting in Standby/Start/Parameters Setting state. LED P ON for phase voltage; LED L ON for phase for line voltage.
25	U V W	Switch output mode: UVW 3-phase, U-phase single, V-phase single, W-phase single in Standby screen.
26	120 220	Quick switch between 120V and 220V in Standby screen.
27	Auto High	Switch between Auto (Auto LED illuminates) and High (High LED illuminates) in Standby/Parameters Setting state. Automatic switch between High (150.1~300.0V) and Low (1.0~150.0V) in Auto state; locked at High (1.0~300.0V) voltage in High state.
28	-Δ U	Quick switch between “Voltage Increase”, “Start Voltage”, “Voltage Decrease” in Start screen. As Auto LED illuminates, switch between Low 150.0V and High 150.1V.
29	+Δ U	
30	Lock	The keys are locked. The Lock LED illuminates. All keys except for STOP and Lock are invalid to avoid misuse. Press Lock key again to release the key lock state. If there is no operation within 5 minutes, the machine will automatically enter the key lock state. After the communication is successful, it will automatically enter the key lock state.

## 1.4.2 Front panel of single-phase power supply

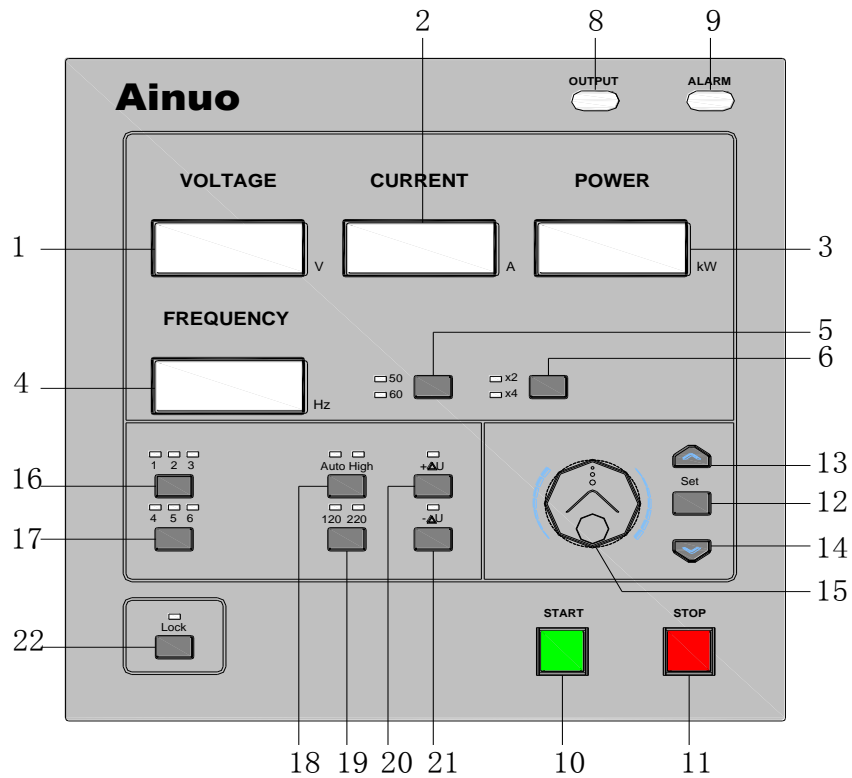



Figure 1-6 Panel of single-phase power supply

Table 1-5 Panel of ANFC single-phase output power supply

No.	Name	Function
1	Voltage display	Display actual output voltage in Running screen; display pre-set voltage in Standby and Pre-set Voltage state.
2	Current display	Display actual output current in Running screen; display Fault No. in Fault state; display 0 in Standby screen.
3	Power display	Display actual output power in Running screen.
4	Frequency display	Display pre-set frequency in Standby and Pre-set state; display actual output frequency in Running screen.
5	50 60	Combined operation in Standby screen. Quick switching between 50, 60, 100, 120, 200, 240Hz.
6	×2 ×4	
8	OUTPUT LED	Green. On in Running screen.
9	ALARM LED	Red. Flashing in Alarm screen.
10	START	OUTPUT LED is ON as the output starts.
11	STOP	Click STOP in Running or Pre-set state to enter the Standby screen; or eliminate sound & light alarm in Alarm screen.
12	Set	Pre-set voltage, frequency, voltage increase/decrease in Standby screen.
13		Increase the corresponding parameter.

14		Decrease the corresponding parameter.
15	Knob	Turn the knob clockwise to increase; turn it counterclockwise to decrease.
16	123	Quick switch between shortcuts 0, 1, 2, 3 in Standby screen.
17	456	Quick switch between shortcuts 0, 4, 5, 6 in Standby screen.
18	Auto High	Switch between Auto (Auto LED illuminates) and High (High LED illuminates) in Standby/Parameters Setting state. Automatic switch between High (150.1~300.0V) and Low (1.0~150.0V) in Auto state; locked at High (1.0~300.0V) voltage in High state.
19	120 220	Quick switch between 120V and 220V in Standby screen.
20	+Δ U	Quick switch between “Voltage Increase”, “Start Voltage”, “Voltage Decrease” in Start screen. As Auto LED illuminates, switch between Low 150.0V and High 150.1V.
21	-Δ U	
22	Lock	The keys are locked. The Lock LED illuminates. All keys except for STOP and Lock are invalid to avoid misuse. Press Lock key again to release the key lock state. If there is no operation within 5 minutes, the machine will automatically enter the key lock state. After the communication is successful, it will automatically enter the key lock state.

## 1.5 Applicable Standards

The following standards apply to this AC power supply:

GB 7260.2-2003 Uninterruptible power systems (UPS) --Part 2: Electromagnetic compatibility (EMC) requirements

GB/T 7260.3-2003 Uninterruptible power systems (UPS) --Part 3: Method of specifying the performance and test requirements

SJ/T 10691-1996 General specification for variable frequency and voltage power supplies

SJ/T 10541-94 General specification of constant voltage power supplies AC output, interference immunity type

Q/AN 21201-2013 Intelligent inverter power supply corporate standard q0100any002-2013

## Chapter 2 Unpacking and Installation

### Guide:

- Unpacking Inspection
- Operating Environment
- Input Line
- Output Line
- Section of Cable

## 2.1 Unpacking Inspection

### 2.1.1 Inspection Prior to Unpacking

Check the package for damage. For any damage, inform the agent to check the goods, and record the damage for the user's benefit.

Unpack in case no damage is found.

### 2.1.2 Unpacking

- (1) Unpack in accordance with the requirements of the package and remove the device
- (2) Check the nameplate first to see if the model is consistent with the order, and if the articles are consistent with the packing list. For any questions, contact Ainuo service center or agents.
- (3) Visual check for any metal mark, scratch etc. Check and tighten connection/fasteners. Check for other abnormalities. For any damage, contact Ainuo service center or agents immediately. Our service center will repair or replace it with new one. Do not return the unit before informing Ainuo Instrument Company or its agent.
- (4) To avoid electricity, never open the cover of unit freely. For any questions, contact Ainuo service center or agents.

## 2.2 Operating Environment

### 2.2.1 General

- (1) Indoor purpose.
- (2) Away from flammable/explosive/corrosive medium: e.g., alcohol, thinner, vitriol etc.
- (3) Away from heat or sunshine.  
Operating temperature: °C~+40°C  
Storage temperature: -10°C~+50°C
- (4) Away from boiler, humidifier, water source etc.

Operating relative humidity: 20~90% RH

Storage relative humidity: 0~90% RH

(5) Away from strong electromagnetic interference sources.

(6) Away from strong vibration or shock.

(7) Good ventilation, no dust. Keep clear within 30 cm away from vent.

(8) Avoid sudden change to temperature to avoid condensate inside the machine. In case any condensate occurs, stop using of this unit.

(9) Away from rain.



### Caution

**If liquid or solid articles enter the power unit through the top vent, the power unit may explode.**

## 2.3 Input Wiring

Open the front door, the I/O terminals are as shown in Figure 2-1. The input line is connected with 3-phase 4-wire +PE terminal block. Connect the grid with the R/S/T/N terminals of the input terminal block. The PE terminal is grounded.

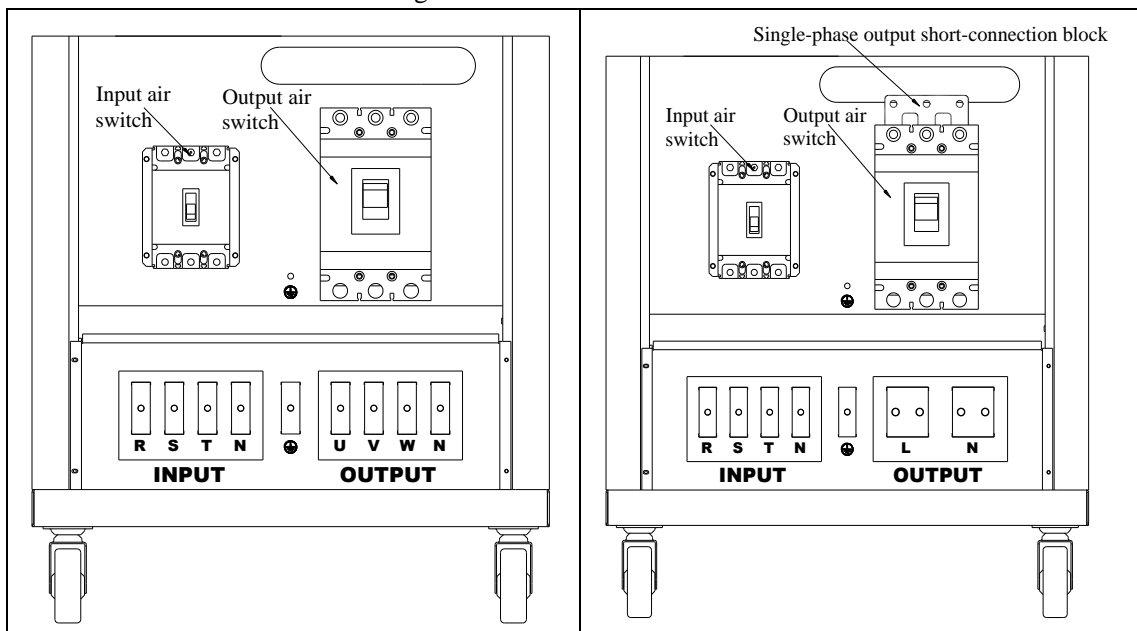
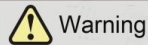

Figure 2-1 I/O wiring (Left: 3-phase power supply; Right: single-phase power supply)



Warning

**Connect the input PE lines correctly, otherwise the power unit will not operate normally due to shock or high interference due to electricity on the power unit.**



Warning

**Connect the N line and RST per the marks. Do not connect the line with N line by mistake, otherwise the power unit will burn or even cause accident.**

## 2.4 Output Wiring

### 2.4.1 3-phase Output Wiring

Open the front door, the I/O terminals are as shown in the left figure of Figure 2-1. 3-phase 4-wire output line is available. Connect the terminal block U/V/W/N of output line with the user's load.

### 2.4.2 Single-phase Output Wiring

Open the front door, the I/O terminals are as shown at the right of Figure 2-1. 2-wire output is available. Connect the line L and N of output terminal block with the user's load.

## 2.5 Section of Cable

The minimum section of I/O lines is listed in Table 2-1.

Table 2-1 Section of I/O line

Power level	Input (mm <sup>2</sup> )			3-phase output (mm <sup>2</sup> )		Single-phase output (mm <sup>2</sup> )	
	PE	N	R S T	U V W	N	L	N
15 kVA	16	10	16	16	16	50	50
20/30kVA	16	10	16	25	25	95	95
45kVA	16	10	25	50	50	95	95
60kVA	16	10	35	50	50	2*95/3*50	2*95/3*50
90kVA	50	10	70	95	95	3*95	3*95
100/120 kVA	50	10	70	95	95	3*95	3*95
150/180 kVA	50	10	95	2*70	2*70	4*95	4*95
200/240/250 kVA	50	10	2*70	2*95	2*95	/	/



**Caution**

**Never use cable with small section to avoid overheat or risk.**

**(1) Indoor** purpose.

- (2) Away from flammable/explosive/corrosive medium: e.g., alcohol, thinner, vitriol etc.
- (3) Away from heat or sunshine.  
Operating temperature: °C ~+40°C  
Storage temperature: -10°C ~+50°C
- (4) Away from boiler, humidifier, water source etc.  
Operating relative humidity: 20~90% RH  
Storage relative humidity: 0~90% RH
- (5) Away from strong electromagnetic interference sources.
- (6) Away from strong vibration or shock.
- (7) Good ventilation, no dust. Keep clear within 30 cm away from vent.
- (8) Avoid sudden change to temperature to avoid condensate inside the machine. In case any condensate occurs, stop using of this unit.
- (9) Away from rain.



**Caution**

**If liquid or solid articles enter the power unit through the top vent, the power unit may explode.**

## 2.3 Input Wiring

Open the front door, the I/O terminals are as shown in Figure 2-1. The input line is connected with 3-phase 4-wire +PE terminal block. Connect the grid with the R/S/T/N terminals of the input terminal block. The PE terminal is grounded.

## Chapter 3 Operation

### Guide:

- Start
- List of Operations
- Shutdown

## 3.1 Preparation and Inspection

- (1) Read the safety and warning marks stamped on the unit before usage.
- (2) No articles blocking ventilation at the top.
- (3) No articles blocking ventilation at the vent
- (4) Connect the I/O lines correctly.



**Notice**

**Make sure to connect the I/O lines correctly.**



**Warning**

**Before turning on the power unit, all earth wire, extension line and units connected with the**

# Ainuo<sup>®</sup> (1) Indoor purpose.

- (2) Away from flammable/explosive/corrosive medium: e.g., alcohol, thinner, vitriol etc.
- (3) Away from heat or sunshine.  
Operating temperature: °C ~+40°C  
Storage temperature: -10°C ~+50°C
- (4) Away from boiler, humidifier, water source etc.  
Operating relative humidity: 20~90% RH  
Storage relative humidity: 0~90% RH
- (5) Away from strong electromagnetic interference sources.
- (6) Away from strong vibration or shock.
- (7) Good ventilation, no dust. Keep clear within 30 cm away from vent.
- (8) Avoid sudden change to temperature to avoid condensate inside the machine. In case any condensate occurs, stop using of this unit.
- (9) Away from rain.



## Caution

**If liquid or solid articles enter the power unit through the top vent, the power unit may explode.**

## 2.3 Input Wiring

Open the front door, the I/O terminals are as shown in Figure 2-1. The input line is connected with 3-phase 4-wire +PE terminal block. Connect the grid with the R/S/T/N terminals of the input terminal block. The PE terminal is grounded.

**instrument must be grounded. Any disconnection of earth will cause potential shock or even personnel injury.**

## 3.2 Start

After connecting the I/O lines correctly, turn on the input air switch, the booting screen will appear on the panel, as shown in Figure 3-1 and Figure 3-2. Self-check of the power supply and the charging for soft start will be performed during booting. The FREQUENCY window will display the counting number during self-check. If the self-check fails, it will switch to the alarm screen. If the self-check is normal, the self-check and soft-start charging is complete after about 8~10 Sec., the AC contacts inside the machine will sound, and the display will switch to the corresponding Standby screen as shown in Figure 3-3 and Figure 3-4.

**(1) Indoor** purpose.

- (2) Away from flammable/explosive/corrosive medium: e.g., alcohol, thinner, vitriol etc.
- (3) Away from heat or sunshine.  
Operating temperature: °C ~+40°C  
Storage temperature: -10°C ~+50°C
- (4) Away from boiler, humidifier, water source etc.  
Operating relative humidity: 20~90% RH  
Storage relative humidity: 0~90% RH
- (5) Away from strong electromagnetic interference sources.
- (6) Away from strong vibration or shock.
- (7) Good ventilation, no dust. Keep clear within 30 cm away from vent.
- (8) Avoid sudden change to temperature to avoid condensate inside the machine. In case any condensate occurs, stop using of this unit.
- (9) Away from rain.



**Caution**

If liquid or solid articles enter the power unit through the top vent, the power unit may explode.

### 2.3 Input Wiring

Open the front door, the I/O terminals are as shown in Figure 2-1. The input line is connected with 3-phase 4-wire +PE terminal block. Connect the grid with the R/S/T/N terminals of the input terminal block. The PE terminal is grounded.

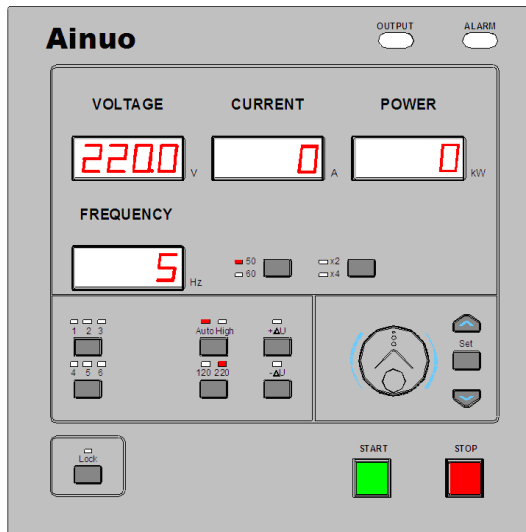
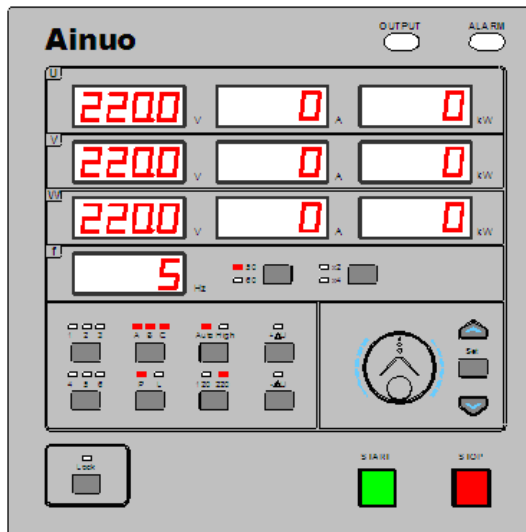

Figure 3-1 3-phase power supply booting screen Figure 3-2 Single-phase power supply booting screen

# Ainuo® (1) Indoor purpose.

- (2) Away from flammable/explosive/corrosive medium: e.g., alcohol, thinner, vitriol etc.
- (3) Away from heat or sunshine.  
Operating temperature: °C ~+40°C  
Storage temperature: -10°C ~+50°C
- (4) Away from boiler, humidifier, water source etc.  
Operating relative humidity: 20~90% RH  
Storage relative humidity: 0~90% RH
- (5) Away from strong electromagnetic interference sources.
- (6) Away from strong vibration or shock.
- (7) Good ventilation, no dust. Keep clear within 30 cm away from vent.
- (8) Avoid sudden change to temperature to avoid condensate inside the machine. In case any condensate occurs, stop using of this unit.
- (9) Away from rain.



## Caution

If liquid or solid articles enter the power unit through the top vent, the power unit may explode.

## 2.3 Input Wiring

Open the front door, the I/O terminals are as shown in Figure 2-1. The input line is connected with 3-phase 4-wire +PE terminal block. Connect the grid with the R/S/T/N terminals of the input terminal block. The PE terminal is grounded.

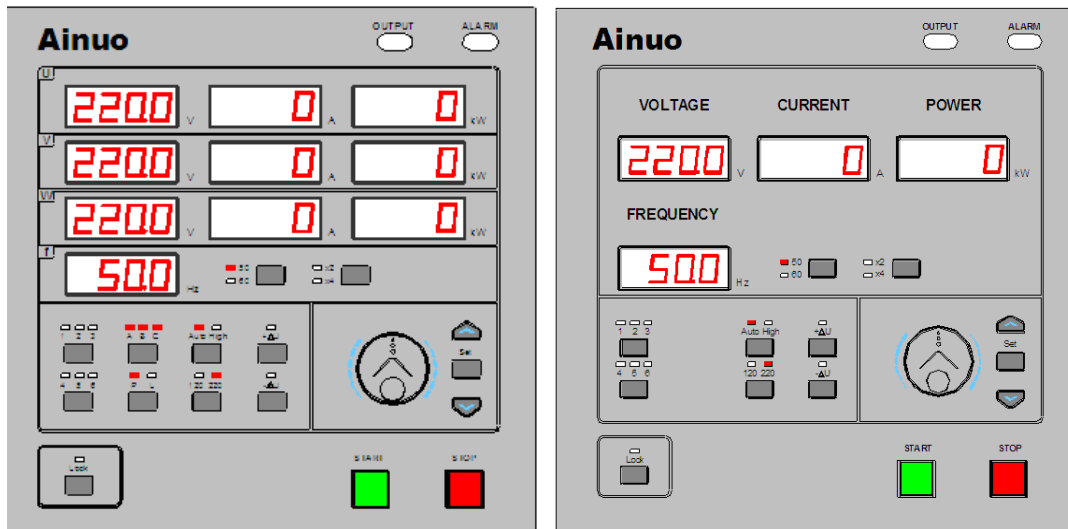

Figure 3-3 3-phase power supply Standby screen Figure 3-4 single-phase power supply Standby screen

## 3.3 List of Operations

Table 3-1 List of Common Operations

Power State	Operations
Standby screen	The power will enter the Standby screen 8~10 Sec. after booting. No operation is valid within this time.
	Click <i>Set</i> key <sup>Note 1</sup> to enter Output Setting screen
	(only 3-phase power supply) Click U V W key to switch between output











**(1) Indoor** purpose.

- (2) Away from flammable/explosive/corrosive medium: e.g., alcohol, thinner, vitriol etc.
- (3) Away from heat or sunshine.  
Operating temperature: °C ~+40°C  
Storage temperature: -10°C ~+50°C
- (4) Away from boiler, humidifier, water source etc.  
Operating relative humidity: 20~90% RH  
Storage relative humidity: 0~90% RH
- (5) Away from strong electromagnetic interference sources.
- (6) Away from strong vibration or shock.
- (7) Good ventilation, no dust. Keep clear within 30 cm away from vent.
- (8) Avoid sudden change to temperature to avoid condensate inside the machine. In case any condensate occurs, stop using of this unit.
- (9) Away from rain.

 **Caution**  
**If liquid or solid articles enter the power unit through the top vent, the power unit may explode.**

### 2.3 Input Wiring

Open the front door, the I/O terminals are as shown in Figure 2-1. The input line is connected with 3-phase 4-wire +PE terminal block. Connect the grid with the R/S/T/N terminals of the input terminal block. The PE terminal is grounded.

	mode: UVW-phase, U-phase single, V-phase single, W-phase single
	Click <i>START</i> key to start the output and enter Start screen
	Press <i>Set</i> key and hold for 3 Sec. <sup>Note 2</sup> to enter System Setting screen
	Press the key <i>456</i> and <i>Set</i> <sup>Note 3</sup> simultaneously to enter Analog Control screen
	Press  and  key simultaneously to monitor the input voltage and internal temperature measurement online. For single-phase power supply. Press  or  key for PageUp/PageDown. Press  and  key simultaneously to return or return automatically after waiting for 10 Sec.
Output Setting screen	To enter Output Setting screen, you can adjust the output voltage after the OUTPUT LED flashes. Click <i>Set</i> key to enter the Output Frequency Adjustment, Start Voltage Increase (%), Start Voltage Decrease (%). The corresponding window flashes. Press  or  key or turn the knob to change the value. Click <i>Set</i> key again to exit Output Setting screen and return to Standby screen.
	Click <i>STOP</i> key to directly exit Output Setting screen and enter Standby screen.
Start screen	Click <i>STOP</i> key to stop output and enter Standby screen. Click <i>Set</i> key to enter the Online Voltage Adjustment, Online Frequency Adjustment screen. The voltage/FREQUENCY windows flash. Press  or  key or turn the knob for online adjustment. (As Auto LED illuminates, Click +Δ U and -Δ U key for High/Low switch between 150.0V and 150.1V) Click <i>Set</i> key again to exit online adjustment screen and return to Start











# Ainuo® (1) Indoor purpose.

- (2) Away from flammable/explosive/corrosive medium: e.g., alcohol, thinner, vitriol etc.
- (3) Away from heat or sunshine.  
Operating temperature: °C ~+40°C  
Storage temperature: -10°C ~+50°C
- (4) Away from boiler, humidifier, water source etc.  
Operating relative humidity: 20~90% RH  
Storage relative humidity: 0~90% RH
- (5) Away from strong electromagnetic interference sources.
- (6) Away from strong vibration or shock.
- (7) Good ventilation, no dust. Keep clear within 30 cm away from vent.
- (8) Avoid sudden change to temperature to avoid condensate inside the machine. In case any condensate occurs, stop using of this unit.
- (9) Away from rain.

 **Caution**  
**If liquid or solid articles enter the power unit through the top vent, the power unit may explode.**

## 2.3 Input Wiring

Open the front door, the I/O terminals are as shown in Figure 2-1. The input line is connected with 3-phase 4-wire +PE terminal block. Connect the grid with the R/S/T/N terminals of the input terminal block. The PE terminal is grounded.

	<p>screen.</p> <p>Click +ΔU and -ΔU key for quick switch between “Voltage Increase”<sup>Note 4</sup>, “Start Voltage”, “Voltage Decrease”<sup>Note 5</sup>.</p> <p>Press  and  key simultaneously to monitor the input voltage and internal temperature measurement online. For single-phase power supply. Press  or  key for PageUp/PageDown. Press  and  key simultaneously to return or return automatically after waiting for 10 Sec.</p>
System Setting screen	<p>To enter System Setting screen. The Address LED flashes. You can adjust the address.</p> <p>Click <i>Set</i> key to adjust baudrate, Line Impedance, Start Ramp, key tone. The corresponding window flashes. Press  or  key or turn the knob to change the value.</p> <p>Click <i>Set</i> key again to exit System Setting screen and return to Standby screen.</p> <p>Click <i>STOP</i> key to directly exit System Setting screen and enter Standby screen.</p> <p>Press <i>Set</i> key and hold for 3 Sec.<sup>Note 2</sup>, the power supply will enter the Operating Data Recorder View screen</p>
Operating Data Recorder View	<p>Press <i>Set</i> key to switch between Alarm Operating Data Recorder (Start with E in FREQUENCY window), Running Operating Data Recorder (Start with U in FREQUENCY window) and Restore Default Settings (display 0 in FREQUENCY window).</p> <p>For Alarm/Running Operating Data Recorder, press  or  key for PageUp/PageDown. Press +ΔU and -ΔU key for switch between groups.</p>

**(1) Indoor** purpose.

- (2) Away from flammable/explosive/corrosive medium: e.g., alcohol, thinner, vitriol etc.
- (3) Away from heat or sunshine.  
Operating temperature: °C ~+40°C  
Storage temperature: -10°C ~+50°C
- (4) Away from boiler, humidifier, water source etc.  
Operating relative humidity: 20~90% RH  
Storage relative humidity: 0~90% RH
- (5) Away from strong electromagnetic interference sources.
- (6) Away from strong vibration or shock.
- (7) Good ventilation, no dust. Keep clear within 30 cm away from vent.
- (8) Avoid sudden change to temperature to avoid condensate inside the machine. In case any condensate occurs, stop using of this unit.
- (9) Away from rain.











**Caution**

**If liquid or solid articles enter the power unit through the top vent, the power unit may explode.**

### 2.3 Input Wiring

Open the front door, the I/O terminals are as shown in Figure 2-1. The input line is connected with 3-phase 4-wire +PE terminal block. Connect the grid with the R/S/T/N terminals of the input terminal block. The PE terminal is grounded.

	In Restore Default Settings screen, press  and  key at the same time to restore default settings.
	Click <i>STOP</i> key to return to Standby screen.
Alarm screen	As any fault is detected, the system will enter Alarm screen and give sound & light alarm.
	Click <i>STOP</i> to eliminate alarm sound, now only the alarm LED flashes; Click <i>STOP</i> again to enter sound & light Alarm screen if the alarm source is not eliminated or an alarm is input; in case of booting self-check alarm, exit the Alarm screen and enter self-check state; in other Alarm screen, exit the Alarm screen and enter Standby screen.
	Press  and  key simultaneously to monitor the input voltage and internal temperature measurement online. For single-phase power supply. Press  or  key for PageUp/PageDown. Press  and  key simultaneously to return
Analog Port Control state	Click <i>STOP</i> key to exit Analog Port Control screen and return to Standby screen
	(only 3-phase power supply) Click U V W key to switch between output mode: UVW-phase, U-phase single, V-phase single, W-phase single
	Analog Port Control state, not affected by communication or other keys, only controlled by the input signal of the analog control port.

Note 1: Click refers to pressing the button and then release it.

Note 2: Press and hold for 3 Sec. means keeping pressing the button for more than 3 seconds.

Note 3: Press button + button is the process by pressing two keys.

Note 4: Voltage Increase: Start Voltage \* (1+ Increase %), not exceeding 300V;

# Ainuo® (1) Indoor purpose.

- (2) Away from flammable/explosive/corrosive medium: e.g., alcohol, thinner, vitriol etc.
- (3) Away from heat or sunshine.  
Operating temperature: °C ~+40°C  
Storage temperature: -10°C ~+50°C
- (4) Away from boiler, humidifier, water source etc.  
Operating relative humidity: 20~90% RH  
Storage relative humidity: 0~90% RH
- (5) Away from strong electromagnetic interference sources.
- (6) Away from strong vibration or shock.
- (7) Good ventilation, no dust. Keep clear within 30 cm away from vent.
- (8) Avoid sudden change to temperature to avoid condensate inside the machine. In case any condensate occurs, stop using of this unit.
- (9) Away from rain.



## Caution

**If liquid or solid articles enter the power unit through the top vent, the power unit may explode.**

## 2.3 Input Wiring

Open the front door, the I/O terminals are as shown in Figure 2-1. The input line is connected with 3-phase 4-wire +PE terminal block. Connect the grid with the R/S/T/N terminals of the input terminal block. The PE terminal is grounded.

Note 5: Voltage Decrease: Start Voltage \* (1- Decrease %), not lower than 1V.

Table 3-2 List of Shortcut Operations

Power State	Operations
Standby screen	Click <i>123</i> and <i>456</i> key for quick switch between 7 shortcuts.
	Click <i>120 220</i> key for quick switch between 120V and 220V.
	Click <i>50 60</i> and $\times 2 \times 4$ key for quick switch between frequency 50Hz, 60Hz, 100Hz, 120Hz, 200Hz, 240Hz.
	(only 3-phase power supply) Click <i>PL</i> key to change voltage setting/display mode to phase/line voltage.
	Click <i>Auto High</i> key to switch between High and Auto.
Output Setting screen	Click <i>120 220</i> key in Voltage Adjustment screen for quick switch between 120V and 220V.
	Click <i>50 60</i> and $\times 2 \times 4$ key in Frequency Adjustment screen for quick switch between frequency 50Hz, 60Hz, 100Hz, 120Hz, 200Hz and 240Hz.
	(only 3-phase power supply) Click <i>PL</i> key to change voltage setting/display mode to phase/line voltage.
	Click <i>Auto High</i> key, switch between voltage High and voltage automatic switch.
Start screen	(only 3-phase power supply) Click <i>PL</i> key to change voltage setting/display mode to phase/line voltage.
All states	Click <i>Lock</i> key to enter or exit Lock screen.

**(1) Indoor** purpose.

- (2) Away from flammable/explosive/corrosive medium: e.g., alcohol, thinner, vitriol etc.
- (3) Away from heat or sunshine.  
Operating temperature: °C ~+40°C  
Storage temperature: -10°C ~+50°C
- (4) Away from boiler, humidifier, water source etc.  
Operating relative humidity: 20~90% RH  
Storage relative humidity: 0~90% RH
- (5) Away from strong electromagnetic interference sources.
- (6) Away from strong vibration or shock.
- (7) Good ventilation, no dust. Keep clear within 30 cm away from vent.
- (8) Avoid sudden change to temperature to avoid condensate inside the machine. In case any condensate occurs, stop using of this unit.
- (9) Away from rain.



**Caution**

**If liquid or solid articles enter the power unit through the top vent, the power unit may explode.**

## 2.3 Input Wiring

Open the front door, the I/O terminals are as shown in Figure 2-1. The input line is connected with 3-phase 4-wire +PE terminal block. Connect the grid with the R/S/T/N terminals of the input terminal block. The PE terminal is grounded.

## 3.4 Shutdown

- (1) If the equipment is in working state, press STOP to stop the output.
- (2) Turn off the input air switch.
- (3) Disconnect the input power line.



**Warning**

Never contact with live parts with body. Prevent electric shock. Do not open the cabinet by non-professionals! The power input is isolated from the output. Never connect the input N-wire with that of the output. Connect the PE cable of the power reliably!



**Warning**

***After the power switch is turned off, the power supply can not be cut off. Switch off the external power supply before disconnecting the input power cable.***

## Chapter 4 Operations on the Panel of 3-phase Power Supply

### 4.1 Standby

After connecting the input/output lines, turn on the power supply, the system will conduct self-check and enter Standby screen after 8~10 Sec. The Standby screen of 3-phase power supply is as shown in Figure 4-1.

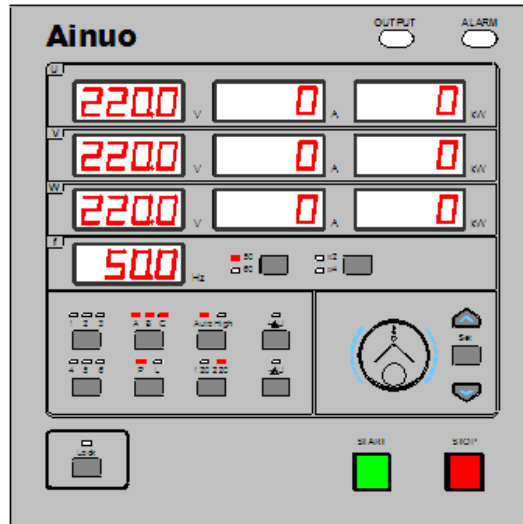

Figure 4-1 Standby of 3-phase power supply

#### 4.1.1 Choose shortcuts

Choose Group in Standby screen. Then click *123* and *456* key for quick switch between 7 shortcuts. As the LEDs of group 1~6 are off, Group 0 is chosen. All following operation of shortcuts, such as change to voltage/frequency and change to output parameters, are subject to the chosen group.

#### 4.1.2 Shortcuts

Click *120 220* key for quick switch the voltage of the shortcut to 120V (120 LED illuminates) or 220V (220 LED illuminates).

Click *50 60* and  $\times 2 \times 4$  key for quick switch the frequency of the shortcut to 50Hz, 60Hz, 100Hz, 120Hz, 200Hz, 240Hz. For example:

As the frequency is not any of the above one, click *50 60* key, the frequency of chosen shortcut is quickly switched to 50Hz (50Hz LED illuminates). Click it again to switch to 60Hz (60Hz LED illuminates). Click  $\times 2 \times 4$  key now, the frequency is quickly switched to 120Hz (60Hz LED illuminates,  $\times 2$  LED illuminates). Click *50 60* key now, the frequency is quickly switched to 100Hz (50Hz LED illuminates,  $\times 2$  LED illuminates). Click  $\times 2 \times 4$  key now, the frequency is quickly switched to 200Hz (50Hz LED illuminates,  $\times 4$  LED illuminates). Other operations are similar.

Click *P L* key to change voltage setting/display mode to phase voltage (P LED illuminates)

/line voltage (L LED illuminates).

Click *U V W* key to switch between output mode: UVW-phase (U, V and W LEDs illuminate), U-phase single (U LED illuminates), V-phase single (V LED illuminates), W-phase single (W LED illuminates).

Click *Auto High* key to switch between High (High LED illuminates) and Auto (Auto LED illuminates). Automatic switch between High (150.1~300.0V) and Low (1.0~150.0V) in Auto state; locked at High (1.0~300.0V) voltage in High state.

Click *Lock* key to enter Lock screen (Lock LED illuminates) and exit Lock screen (Lock LED goes off).

### 4.1.3 Switch to other screen

Click *Set* key to enter Output Setting screen. See Section 4.2.

Click *START* key, the power supply will start output based on the setting of current shortcut and switch to the Start screen. See Section 4.3.

Press *Set* key and hold for 3 Sec. to enter System Setting screen. See Section 4.4.

Press *456* + *Set* key to enter Analog Control screen. See Section 7.

## 4.2 Output Setting



Click *Set* key once in Standby screen to enter Output Setting screen.

In Output Setting screen, the VOLTAGE window flashes to display the voltage setting; the frequency setting displays in FREQUENCY window; the Increase setting displays in V-phase CURRENT window, the Decrease setting displays in V-phase POWER window.

### 4.2.1 Change Output Voltage Setting

Click *Set* key once in Standby screen to enter Output Voltage Setting screen.

In Output Voltage Setting screen, the VOLTAGE window flashes (in UVW-phase output mode, the UVW-phase VOLTAGE windows flash. In U-phase output mode, the U-phase VOLTAGE window flashes. In V-phase output mode, the V-phase VOLTAGE window flashes. In W-phase output mode, the W-phase VOLTAGE window flashes).

Press  or  key or turn the knob to change the voltage setting.

Phase voltage setting: 1.0V~300.0V; line voltage setting: 1.7V~519.6V.

Click *120 220* key for quick switch the voltage settings to 120V (120 LED illuminates) or 220V (220 LED illuminates).

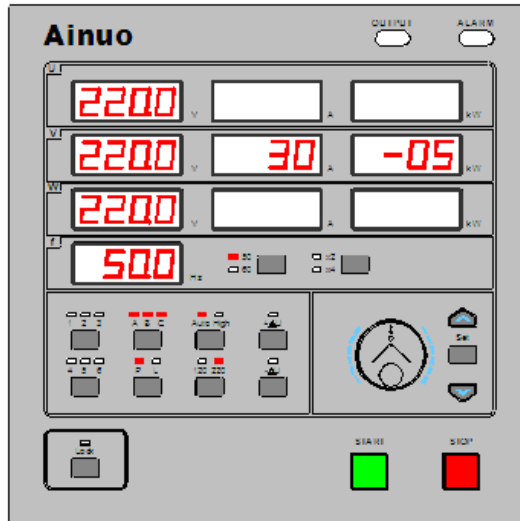



Figure 4-2 Output Setting of 3-phase power supply

Click *Set* key to enter Output Frequency Setting screen.

## 4.2.2 Change Output Frequency Setting

Click *Set* key twice in Standby screen to enter Output Frequency Setting screen.

In Output Frequency Setting screen, the FREQUENCY window flashes.

Press  or  key or turn the knob to change the frequency parameter (45.0~65.0Hz).

As the frequency exceeds 65.0Hz, increase/decrease by 100Hz, 120Hz, 200Hz, 240Hz.



Click *50 60* and *×2 ×4* key for quick switch the frequency of the shortcut to 50Hz, 60Hz, 100Hz, 120Hz, 200Hz or 240Hz.

Click *Set* key to enter Increase Setting screen.

## 4.2.3 Change Increase Setting

Click *Set* key three times in Standby screen to enter the output Increase Setting screen.

In Increase Setting state, the +Δ U LED illuminates, and V-phase CURRENT window flashes.



Press  or  key or turn the knob to change the Increase Setting (5%~30%).

Click *Set* key to enter Decrease Setting screen.

## 4.2.4 Change Decrease Setting

Click *Set* key four times in Standby screen to enter the output Decrease Setting screen.

In Decrease Setting state, the - Δ U LED illuminates, and V-phase CURRENT window flashes.

Press  or  key or turn the knob to change the Decrease Setting (-5%~30%).

## 4.2.5 Shortcuts

Click *PL* key to change voltage setting/display mode to phase voltage (P LED illuminates) /line voltage (L LED illuminates).

Click *Auto High* key to switch between High (High LED illuminates) and Auto (Auto LED

illuminates).

Click *Lock* key to enter Lock screen (Lock LED illuminates) and exit Lock screen (Lock LED goes off).

### 4.2.6 Exit Output Setting screen

Click *STOP* key at any time to save current shortcut setting, exit Output Setting screen and enter Standby screen.

Click *Set* key in Decrease Setting screen to save current shortcut setting, exit Output Setting screen and return to Standby screen.

## 4.3 Start screen

Press *START* key in Standby screen to start the power supply, the OUTPUT LED illuminates. if the Start Ramp Time in System Setting is not 0, the power supply will enter Start Ramp screen, and out voltage will increase gradually within set time to the voltage setting, entering the Start screen.

In Start Ramp screen and Start screen, the actual output measurement displays on the panel.

In Start screen, click *Set* key to enter Online Voltage Adjustment screen.

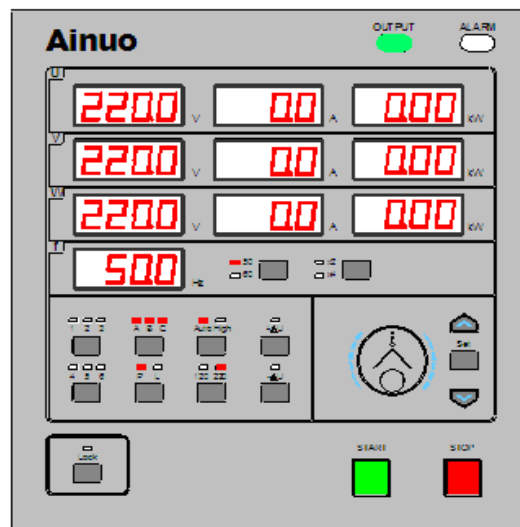



Figure 4-3 Start of 3-phase power supply

### 4.3.1 Online Voltage Adjustment

Click *Set* key once in Start screen to enter Online Voltage Adjustment screen.

In Online Voltage Adjustment screen, the VOLTAGE window flashes (in UVW-phase output mode, the UVW-phase VOLTAGE windows flash. In U-phase output mode, the U-phase VOLTAGE window flashes. In V-phase output mode, the V-phase VOLTAGE window flashes. In W-phase output mode, the W-phase VOLTAGE window flashes).

Press  or  key or turn the knob to adjust the output voltage online.



In Auto level, to increase the voltage as it exceeds 150.0V (Press +ΔU key) or decrease the voltage as it exceeds 150.1V (Press -ΔU key), hard switch will occur, and the output will be interrupted for 40ms.

Click +Δ U and -Δ U key for quick switch between “Voltage Increase”, “Start Voltage”, “Voltage Decrease”. Where:

Voltage Increase: Start Voltage \* (1+ Increase %), not exceeding 300V;



Voltage Decrease: Start Voltage \* (1- Decrease %), not lower than 1V.

Click *Set* key to enter Online Frequency Adjustment screen.

### 4.3.2 Online Frequency Adjustment

Click *Set* key twice in Start screen to enter Online Frequency Adjustment screen.

In Online Frequency Adjustment screen, the FREQUENCY window flashes.

Press  or  key or turn the knob to adjust the output frequency online (45.0~65.0Hz).

Click *Set* key to exit Online Voltage Adjustment screen and Online Frequency Adjustment screen.

### 4.3.3 Shortcuts

Click +Δ U and -Δ U key in Start screen for quick switch between “Voltage Increase”, “Start Voltage” and “Voltage Decrease”.

Click *PL* key to change voltage setting/display mode to phase voltage (P LED illuminates) /line voltage (L LED illuminates).

Click *Lock* key to enter Lock screen (Lock LED illuminates) and exit Lock screen (Lock LED goes off).

### 4.3.4 STOP output

Click *STOP* key in Start Ramp screen and Start screen, the power supply stops output to enter Standby screen.

## 4.4 System Setting

The System Setting screen is as shown in the following figure. The address displays in the V-phase VOLTAGE window. The baudrate displays in V-phase CURRENT window. The Line Impedance displays in V-phase POWER window. The Start Ramp Time displays in FREQUENCY window.

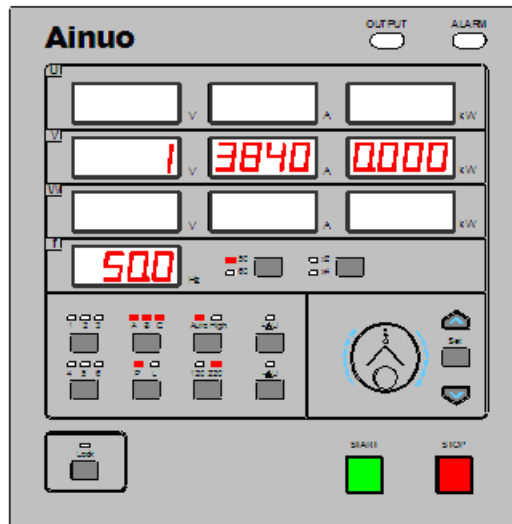



Figure 4-4 System Setting of 3-phase power supply

#### 4.4.1 OCP current Adjustment



Press *Set* key and hold for 3 Sec. in Standby screen to enter OCP current Adjustment screen.

In OCP current Adjustment screen, the VOLTAGE (V phase) window flashes. If null is showed in the windows, OCP function is closed. Press  or  key or turn the knob to adjust the value. The max setting value should be less than rated current of Power Supply.

#### 4.4.2 Start Ramp Adjustment

Press *Set* key and hold for 3 Sec. in Standby screen. Then click *Set* key once to enter Start Ramp Setting screen.



In Start Ramp Setting screen, the current (V phase) window flashes.

Press  or  key or turn the knob to change the value. Start Ramp Setting Range: 0.0~99.9 Sec.

#### 4.4.3 Line Impedance Adjustment

Press *Set* key and hold for 3 Sec. in Standby screen. Then click *Set* key twice to enter Line Impedance Setting screen.



In Line Impedance Setting screen, the POWER (V-phase) window flashes.

Press  or  key or turn the knob to change the line impedance. Line Impedance Setting Range: 0.000~0.500  $\Omega$ .

#### 4.4.4 Key tone Adjustment

Press *Set* key and hold for 3 Sec. in Standby screen. Then click *Set* key 3 times to enter Key Tone Setting screen.



In Key Tone Setting screen, the window VOLTAGE (W phase) flashes.

Press  or  key or turn the knob to change the key tone. 0 means key tone is disenable; 1 means key tone is enabled. As the key tone is enabled, short sound will be given as press keys or turn knobs.

## 4.4.5 Address Adjustment

Press *Set* key and hold for 3 Sec. in Standby screen. Then click *Set* key 4 times to enter Address Setting screen.



In Address Setting screen, the CURRENT window(W phase) flashes.

Press  or  key or turn the knob to change the address. Address Setting Range:1~255

## 4.4.6 Baudrate Adjustment

Press *Set* key and hold for 3 Sec. in Standby screen. Then click *Set* key 5 times to enter Baudrate Setting screen.

In Baudrate Setting screen, the POWER window(W phase) flashes.

Press  or  key or turn the knob to change the baudrate: 120、240、480、960、1920、3840, unit is 10\*bps. For GPIB or Ethernet port, the baudrate can't be changed and fixed at 38400 bps.

## 4.4.7 Exit System Setting

Click *STOP* key at any time to save current parameter setting, exit Setting screen and enter Standby screen.

Click *Set* key in Baudrate Setting screen to save System Setting and return to Standby screen.

## 4.5 Alarm screen

In case of fault, the power supply will automatically perform protection and display fault code (For Table of alarm code, see Annex I. For troubleshooting of simple faults, see section 6.2). The output stops. The alarm LED flashes, giving alarm sound, displaying the alarm code, as shown in the figure.

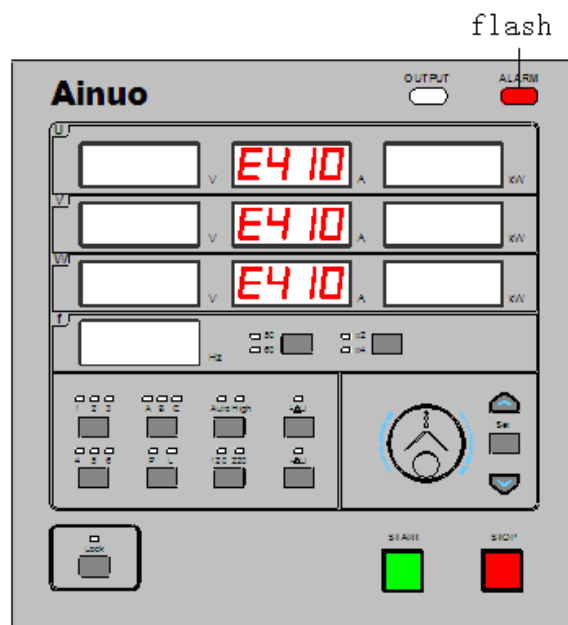

Figure 4-5 Alarm of 3-phase power supply

### 4.5.1 Eliminating of Alarm

Click STOP to eliminate alarm sound, now only the ALARM LED flashes;

Click STOP again to enter sound & light alarm state if the alarm source is not eliminated; in case of self-check alarm during booting, exit the Alarm screen and enter self-check state; in other Alarm screen, exit the Alarm screen and enter Standby screen.

Note 1: E200 means abnormal input. Now it is impossible to exit the alarm state after clicking STOP. Turn off the power and check the input line. Turn on the power again if all are normal.

### 4.6 Online Monitoring

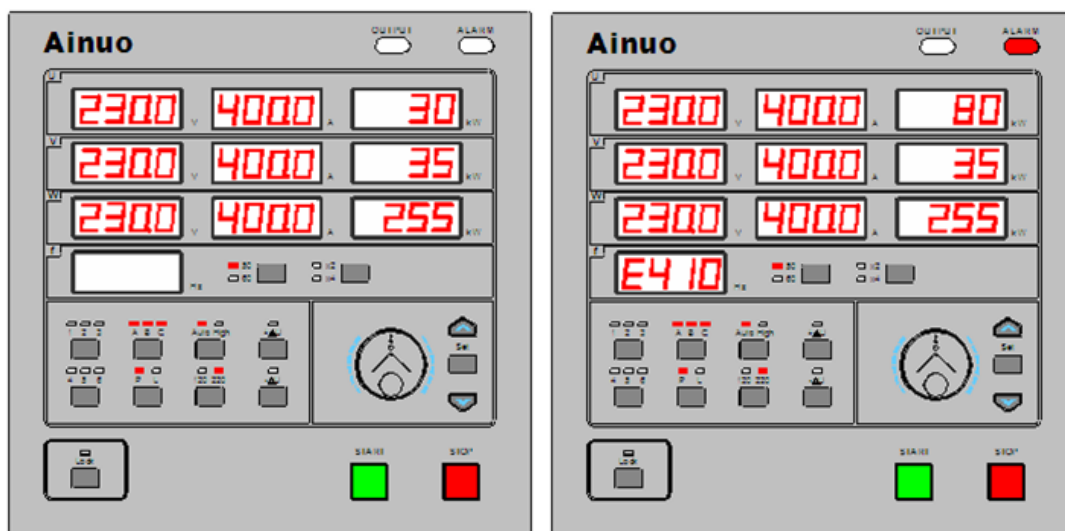

Figure 4-6 Standby/Running Online Monitoring Figure 4-7 Alarm Online Monitoring

Press and key at the same time in Standby screen, Running screen, Alarm screen for online monitoring of input phase voltage (left 3 VOLTAGE windows), input line voltage (middle 3 CURRENT windows) and internal temperature (right POWER windows for IGBT temperature, transformer temperature and fan control speed). Press and key at the same time in Online Monitoring screen to return.

If there is no operation within 10 Sec. in Standby/Running Online Monitoring screen, it will automatically return.



### 4.7 Operating Data Recorder

Press *Set* key and hold for 3 Sec. in System Setting screen to enter Alarm Operating Data Recorder screen.

Press *Set* key to switch between Alarm Operating Data Recorder (Start with E in FREQUENCY window), Running Operating Data Recorder (Start with U in FREQUENCY window) and Restore Default Settings (display 0 in FREQUENCY window).

The Alarm/Running Operating Data Recorder contains 20 groups of data. 0 means no

record (no display in windows other than FREQUENCY window); the first one is the latest record.

For Alarm/Running Operating Data Recorder, press  or  key for PageUp/PageDown. Press +ΔU and -ΔU key for switch between groups.

Click *STOP* key to return to Standby screen.

## 4.7.1 Alarm Operating Data Recorder

The E + 3 digit in FREQUENCY window means Alarm Operating Data Recorder. Add a record for each alarm (Max. 20 records), as shown in Figure 4-8.

**Content in Page 1:** VOLTAGE window: Alarm Code, output frequency, Running time (h)

**Content in Page 2:** VOLTAGE window: 3-phase input phase voltage  
 CURRENT window: 3-phase input line voltage  
 POWER window: IGBT and transformer temperature, fan speed

**Content in Page 3:** Alarm output voltage, current, power

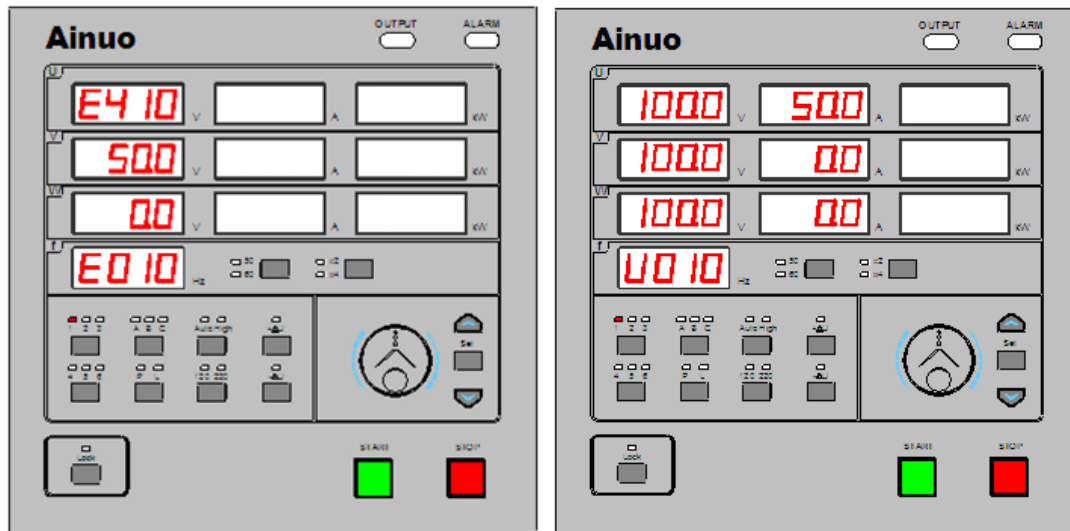



Figure 4-8 Page 1 of Alarm Operating Data Recorder Figure 4-9 Running Operating Data Recorder

## 4.7.2 Running Operating Data Recorder

The U + 3 digit in FREQUENCY window means Running Operating Data Recorder. Add a record for each start (Max. 20 records), as shown in Figure 4-9.

**Display content:** VOLTAGE window: start voltage setting  
 CURRENT window: start frequency setting, Start Ramp Time, Running time (h)

## 4.7.3 Restore Default Settings

Press  and  keys in Restore Default Settings screen to restore default settings, the display in FREQUENCY window changes to 1 from 0, meaning it is successful to restore default settings.

## Chapter 5 Operations on the Panel of Single-phase Power Supply

### 5.1 Standby

After connecting the input/output lines, turn on the power supply, the system will conduct self-check and enter Standby screen after 8~10 Sec. The Standby screen of 3-phase power supply is as shown in the following figure.

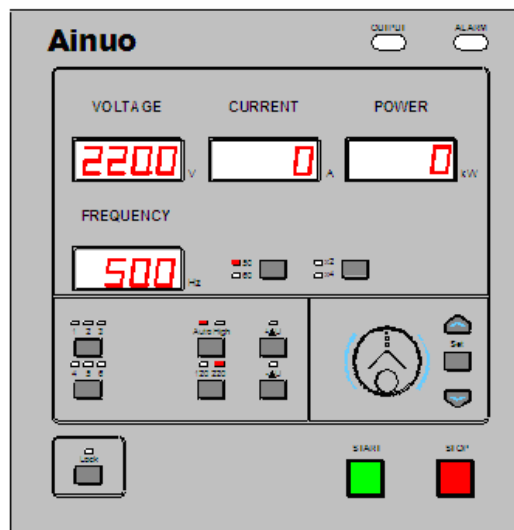

Figure 5-1 Standby of single-phase power supply

#### 5.1.1 Choose shortcuts

Choose Group in Standby screen. Then click *123* and *456* key for quick switch between 7 shortcuts. As the LEDs of group 1~6 are off, Group 0 is chosen. All following operation of shortcuts, such as change to voltage/frequency and change to output parameters are subject to the chosen group.

#### 5.1.2 Shortcuts

Click *120 220* key for quick switch the voltage of the shortcut to 120V (120 LED illuminates) or 220V (220 LED illuminates).

Click *50 60* and  $\times 2$   $\times 4$  key for quick switch the frequency of the shortcut to 50Hz, 60Hz, 100Hz, 120Hz, 200Hz, 240Hz. For example:

As the frequency is not any of the above one, click *50 60* key, the frequency of chosen shortcut is quickly switched to 50Hz (50Hz LED illuminates). Click it again to switch to 60Hz (60Hz LED illuminates). Click  $\times 2$   $\times 4$  key now, the frequency is quickly switched to 120Hz (60Hz LED illuminates,  $\times 2$  LED illuminates). Click *50 60* key now, the frequency is quickly switched to 100Hz (50Hz LED illuminates,  $\times 2$  LED illuminates). Click  $\times 2$   $\times 4$  key now, the frequency is quickly switched to 200Hz (50Hz LED illuminates,  $\times 4$  LED illuminates). Other operations are similar.

Click *Auto High* key to switch between High (High LED illuminates) and Auto (Auto LED illuminates).

Click *Lock* key to enter Lock screen (Lock LED illuminates) and exit Lock screen (Lock LED goes off).

### 5.1.3 Switch to other screen

Click *Set* key to enter Output Setting screen. See Section 5.2.

Click *START* key, the power supply will start output based on the setting of current shortcut and switch to the Start screen. See Section 5.3.

Press *Set* key and hold for 3 Sec. to enter System Setting screen. See Section 5.4.

Press *456* + *Set* key to enter Analog Control screen. See Section 7.



## 5.2 Output Setting

In Output Setting screen, the VOLTAGE window flashes to display the voltage setting; the frequency setting displays in FREQUENCY window; the Increase setting displays in CURRENT window, the Decrease setting displays in POWER window.

### 5.2.1 Change Output Voltage Setting

Click *Set* key once in Standby screen to enter Output Voltage Setting screen.

After entering Output Setting screen, enter the Output Voltage Setting screen first, the VOLTAGE window flashes.

Press  or  key or turn the knob to change the voltage setting (1.0V~300.0V).

Click *120 220* key for quick switch the voltage settings to 120V (120 LED illuminates) or 220V (220 LED illuminates).

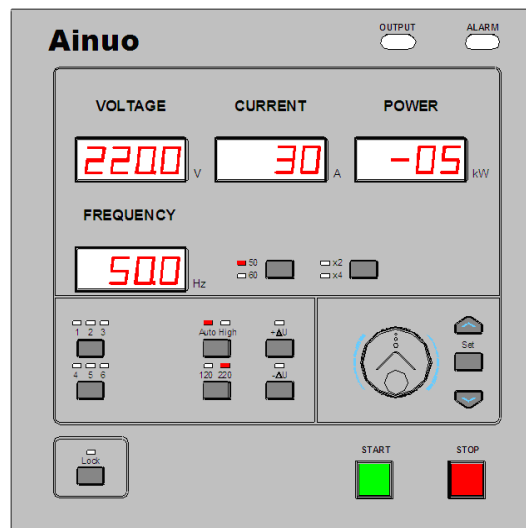



Figure 5-2 Output Setting of single-phase power supply

Click *Set* key to enter Output Frequency Setting screen.

### 5.2.2 Change Output Frequency Setting

Click *Set* key twice in Standby screen to enter Output Frequency Setting screen.

In Output Frequency Setting screen, the FREQUENCY window flashes.

Press  or  key or turn the knob to change the frequency parameter (45.0~65.0Hz).

As the frequency exceeds 65.0Hz, increase/decrease by 100Hz, 120Hz, 200Hz, 240Hz.



Click 50 60 and  $\times 2$   $\times 4$  key for quick switch the frequency of the shortcut to 50Hz, 60Hz, 100Hz, 120Hz, 200Hz or 240Hz.

Click *Set* key to enter Increase Setting screen.

### 5.2.3 Change Increase Setting

Click *Set* key three times in Standby screen to enter the output Increase Setting screen.

In Increase Setting state, the  $+\Delta U$  LED illuminates, and V-phase CURRENT window flashes.



Press  or  key or turn the knob to change the Increase Setting (5%~30%).

Click *Set* key to enter Decrease Setting screen.

### 5.2.4 Change Decrease Setting

Click *Set* key four times in Standby screen to enter the output Decrease Setting screen.

In Decrease Setting state, the  $-\Delta U$  LED illuminates, and V-phase CURRENT window flashes.

Press  or  key or turn the knob to change the Decrease Setting (-5%~-30%).

### 5.2.5 Shortcuts

Click *Auto High* key to switch between High (High LED illuminates) and Auto (Auto LED illuminates).

Click *Lock* key to enter Lock screen (Lock LED illuminates) and exit Lock screen (Lock LED goes off).

### 5.2.6 Exit Output Setting screen

Click *STOP* key at any time to save current shortcut setting, exit Output Setting screen and enter Standby screen.

Click *Set* key in Decrease Setting screen to save current shortcut setting, exit Output Setting screen and return to Standby screen.

## 5.3 Start screen

Press *START* key in Standby screen to start the power supply, the OUTPUT LED illuminates. if the Start Ramp Time in System Setting is not 0, the power supply will enter Start Ramp screen, and out voltage will increase gradually within set time to the voltage setting, entering the Start screen.

In Start Ramp screen and Start screen, the actual output measurement displays on the panel.

In Start screen, click *Set* key to enter Online Voltage Adjustment screen.

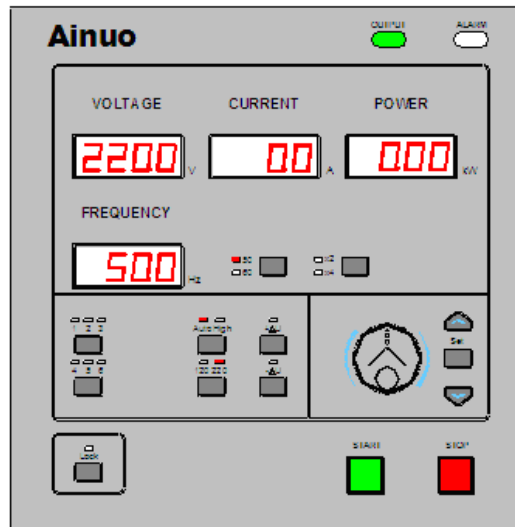



Figure 5-3 Start of single-phase power supply

### 5.3.1 Online Voltage Adjustment

Click *Set* key once in Start screen to enter Online Voltage Adjustment screen.  
In Online Voltage Adjustment screen, the VOLTAGE window flashes.  
Press  or  key or turn the knob to adjust the output voltage online.



**In Auto level, to increase the voltage as it exceeds 150.0V (Press +ΔU key) or decrease the voltage as it exceeds 150.1V (Press -ΔU key), hard switch will occur, and the output will be interrupted for 40ms.**

Click +Δ U and -Δ U key for quick switch between “Voltage Increase”, “Start Voltage”, “Voltage Decrease”. Where:

Voltage Increase: Start Voltage \* (1+ Increase %), not exceeding 300V;



Voltage Decrease: Start Voltage \* (1- Decrease %), not lower than 1V.

Click *Set* key to enter Online Frequency Adjustment screen.

### 5.3.2 Online Frequency Adjustment

Click *Set* key twice in Start screen to enter Online Frequency Adjustment screen.

In Online Frequency Adjustment screen, the FREQUENCY window flashes.

Press  or  key or turn the knob to adjust the output frequency online (45.0~65.0Hz).

Click *Set* key to exit Online Voltage Adjustment screen and Online Frequency Adjustment screen.

### 5.3.3 Shortcuts

Click +Δ U and -Δ U key in Start screen for quick switch between “Voltage Increase”, “Start Voltage” and “Voltage Decrease”.

Click *Lock* key to enter Lock screen (Lock LED illuminates) and exit Lock screen (Lock LED goes off).

### 5.3.4 STOP output

Click *STOP* key in Start Ramp screen and Start screen, the power supply stops output to enter Standby screen.

## 5.4 System Setting

The System Setting screen is as shown in the following figure. The address displays in the VOLTAGE window. The baudrate displays in CURRENT window. The Line Impedance displays in POWER window. The Start Ramp Time displays in FREQUENCY window.

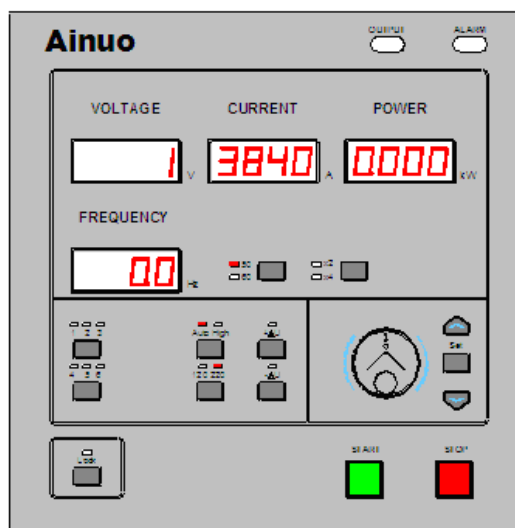

Figure 5-4 System Setting of single-phase power supply

### 5.4.1 OCP current Adjustment

Press *Set* key and hold for 3 Sec. in Standby screen to enter OCP current Adjustment screen.

In OCP current Adjustment screen, the VOLTAGE (V phase) window flashes. If null is showed in the windows, OCP function is closed. Press or key or turn the knob to adjust the value. The max setting value should be less than rated current of Power Supply.

### 5.4.2 Start Ramp Adjustment

Press *Set* key and hold for 3 Sec. in Standby screen. Then click *Set* key once to enter Start Ramp Setting screen.

In Start Ramp Setting screen, the current (V phase) window flashes.

Press or key or turn the knob to change the value. Start Ramp Setting Range: 0.0~99.9 Sec.

### 5.4.3 Line Impedance Adjustment

Press *Set* key and hold for 3 Sec. in Standby screen. Then click *Set* key twice to enter Line Impedance Setting screen.

In Line Impedance Setting screen, the POWER (V-phase) window flashes.



Press or key or turn the knob to change the line impedance. Line Impedance

Setting Range:0.000~0.500 Ω .

### 5.4.4 Key tone Adjustment

Press *Set* key and hold for 3 Sec. in Standby screen. Then click *Set* key 3 times to enter Key Tone Setting screen.



In Key Tone Setting screen, the window VOLTAGE (V phase) flashes.

Press  or  key or turn the knob to change the key tone. 0 means key tone is disable; 1 means key tone is enabled. As the key tone is enabled, short sound will be given as press keys or turn knobs.

### 5.4.5 Address Adjustment

Press *Set* key and hold for 3 Sec. in Standby screen. Then click *Set* key 4 times to enter Address Setting screen.



In Address Setting screen, the CURRENT window(V phase) flashes.

Press  or  key or turn the knob to change the address. Address Setting Range:1~255

### 5.4.6 Baudrate Adjustment

Press *Set* key and hold for 3 Sec. in Standby screen. Then click *Set* key 5 times to enter Baudrate Setting screen.

In Baudrate Setting screen, the POWER window(V phase) flashes.

Press  or  key or turn the knob to change the baudrate: 120, 960, 1920, 3840, unit is bps. For GPIB or Ethernet port, the baudrate can't be changed and fixed at 38400 bps.

### 5.4.7 Exit System Setting

Click *STOP* key at any time to save current parameter setting, exit Setting screen and enter Standby screen.

Click *Set* key in Baudrate Setting screen to save System Setting and return to Standby screen.

## 5.5 Alarm screen

In case of fault, the power supply will automatically perform protection and display fault code (For Table of alarm code, see Annex I. For troubleshooting of simple faults, see section 6.2). The output stops. The alarm LED flashes, giving alarm sound, displaying the alarm code, as shown in the figure.

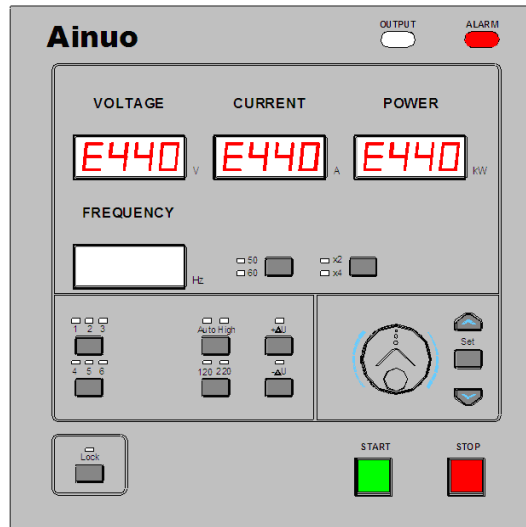

Figure 5-5 Alarm of single-phase power supply



### 5.5.1 Eliminating of Alarm

Click STOP to eliminate alarm sound, now only the ALARM LED flashes;

Click STOP again to enter sound & light alarm state if the alarm source is not eliminated; in case of self-check alarm during booting, exit the Alarm screen and enter self-check state; in other Alarm screen, exit the Alarm screen and enter Standby screen.

Note 1: E200 means abnormal input. Now it is impossible to exit the alarm state after clicking STOP. Turn off the power and check the input line. Turn on the power again if all are normal.

### 5.6 Online Monitoring

Press  and  key at the same time in Standby screen, Running screen, Alarm screen for online monitoring of input phase voltage (Page 1, Figure 5-6), input line voltage (Page 2) and internal temperature (Page 3, Figure 5-7, for IGBT temperature, transformer temperature and fan control speed).

Press  and  key at the same time in Online Monitoring screen to return.

Press  or  key in Online Monitoring screen for PageUp/PageDown.

If there is no operation within 10 Sec. in Standby/Running Online Monitoring screen, it will automatically return.

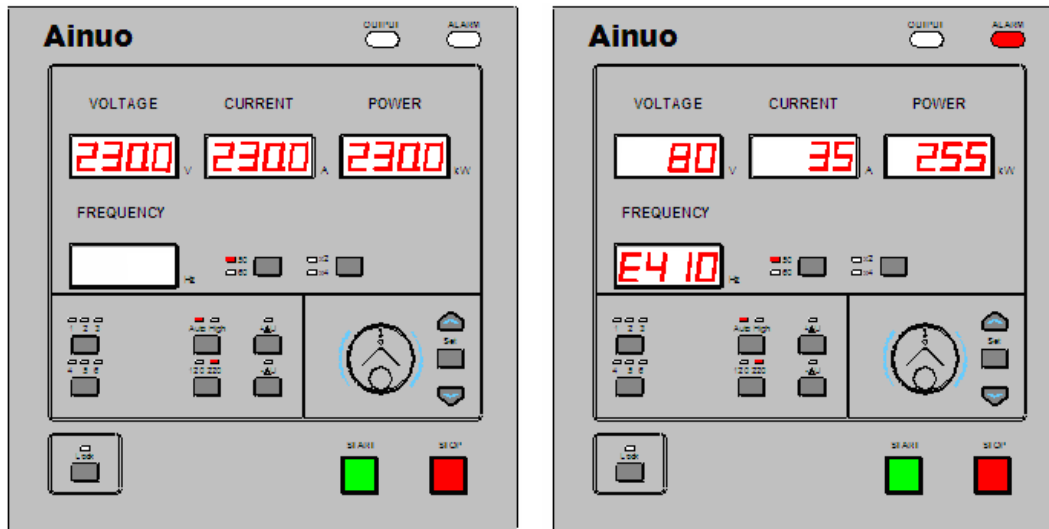



Figure 5-6 Standby/Running Online Monitoring, Page 1 Figure 5-7 Alarm Online Monitoring, Page 2

## 5.7 Operating Data Recorder

Press *Set* key and hold for 3 Sec. in System Setting screen to enter Alarm Operating Data Recorder screen.

Press *Set* key to switch between Alarm Operating Data Recorder (Start with E in FREQUENCY window), Running Operating Data Recorder (Start with U in FREQUENCY window) and Restore Default Settings (display 0 in FREQUENCY window).

The Alarm/Running Operating Data Recorder contains 20 groups of data. 0 means no record (no display in windows other than FREQUENCY window); the first one is the latest record.

For Alarm/Running Operating Data Recorder, press  or  key for PageUp/PageDown. Press +ΔU and -ΔU key for switch between groups.

Click *STOP* key to return to Standby screen.

### 5.7.1 Alarm Operating Data Recorder

The E + 3 digit in FREQUENCY window means Alarm Operating Data Recorder. Add a record for each alarm (Max. 20 records), as shown in Figure 5-8.

**Content in Page 1:** Alarm Code, output frequency, Running time (h)

**Content in Page 2:** 3-phase input phase voltage

**Content in Page 3:** 3-phase input line voltage

**Content in Page 4:** IGBT and transformer temperature, fan speed

**Content in Page 5:** Alarm group 1 output voltage, current, power

**Content in Page 6:** Alarm group 2 output voltage, current, power (N/A for some models)

**Content in Page 7:** Alarm group 3 output voltage, current, power (N/A for some models)

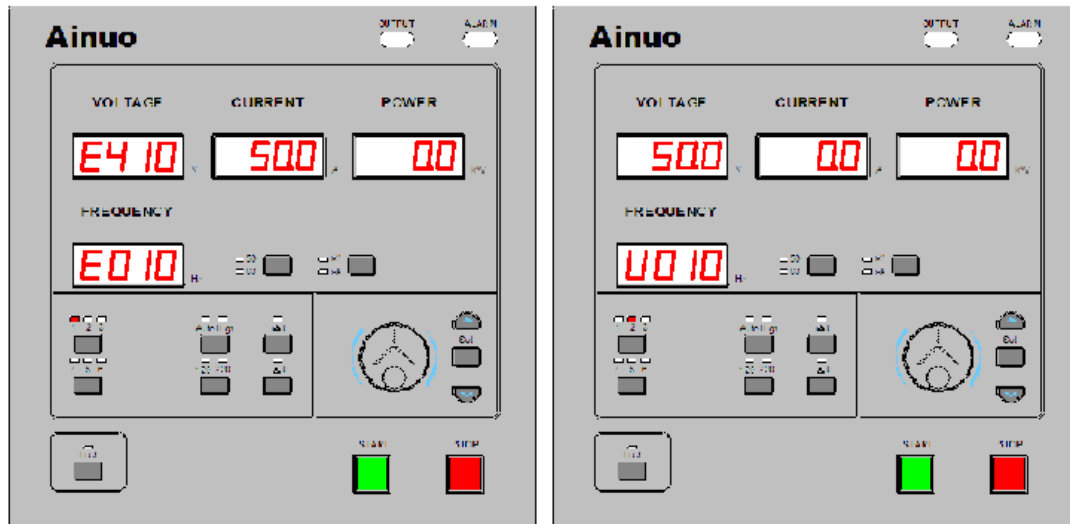

Figure 5-8 Alarm Operating Data Recorder, Page 1 Figure 5-9 Running Operating Data Recorder, Page 2



### 5.7.2 Running Operating Data Recorder

The U + 3 digit in FREQUENCY window means Running Operating Data Recorder. Add a record for each start (Max. 20 records), as shown in Figure 5-9.

**Content in Page 1:** start voltage setting.

**Content in Page 1:** start frequency setting, Start Ramp Time, Running time (h)

### 5.7.3 Restore Default Settings

Press  and  keys in Restore Default Settings screen to restore default settings, the display in FREQUENCY window changes to 1 from 0, meaning it is successful to restore default settings.

## Chapter 6 Inspection and Maintenance

### Guide:

- Maintenance and Care
- Troubleshooting
- Storage and Transportation

### 6.1 Maintenance and Care

#### 6.1.1 Daily Maintenance

- (1) For long term storage, turn on the power monthly lasting for at least 30 minutes.
- (2) Keep the place clean and dry, free of corrosion.
- (3) Do not open the power supply by persons other than professionals, to avoid personal injury or damage to the equipment.
- (4) Do not place heavy objects, tools and other articles on the power line to avoid damage to the insulation, prevent exposure of bare wire and personal injury; do not place the power line in place with frequent travel to avoid any danger.
- (5) Do not stack articles around the power supply to prevent clogging of vents.

#### 6.1.2 Maintenance

It is recommended to perform following operation at least every year.

- (1) Check the insulating layer of I/O lines and terminals for damage regularly. For any damage, replace in time to avoid shock.
- (2) Check and tighten I/O lines regularly to avoid overheat due to loosen electric lines.
- (3) Check all warning marks regularly, replace if necessary.
- (4) Check all exposed parts.
- (5) Check the function and buttons regularly.
- (6) Check the fan.

#### 6.1.3 Repair by Users

Never open the case freely to avoid shock; never change the circuit or parts. In case of any modification, the warrantee will become automatically invalid. In case the unit is modified freely, our technical personals will repair the unit and charge accordingly.

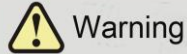
**Warning**

Non-professionals shall not open the unit, to avoid personnel injury or damage to device.

### 6.1.4 Maintenance and Care for Long-term Storage

- (1) Keep the unit in proper unit for long term storage. See 6.3.1 for detail.
- (2) Clean the unit before starting.
- (3) Prepare and check before starting. See 3.1 for detail.
- (4) Check if the unit works normally after starting. For any abnormalities or fault, stop immediately. Pull out the power line or shut off the power unit from the distribution box. Never use the unit before it is repaired.

## 6.2 Troubleshooting

**Warning**

**Only professionals can repair or maintain this unit, to avoid personnel injury or even death.**

If the faults cannot be handled according to the following table, do not turn on the machine again. Please call Ainuo customer service for maintenance. For meaning of specific alarm codes, see Annex I.

Table 6-1 Common Faults and Measures

Fault/Code	Reason	Measures
No display after starting	(1) Power unit not ON; (2) Voltage abnormal.	(1) Check the voltage.
E410 E440 E470 E412 E442 E472 E500 E312 E342 E372 E313 E343 E373	(1) Start load current too high (For example: start of inductance/motor load); (2) Output terminal short-circuit; (3) Section of input cable too low or circuit resistance too high; (4) Ambient temperature too high, or bad radiation, causing overheat of power device. (5) Load current too high; (6) Load current crest factor too high (For example: rectifier load).	(1) Decrease load (for example, switchover of load by batch), or increase capacity of power unit, enable Start Ramp function; (2) Check for short-circuit and handle; (3) Use input power line of proper section based on the capacity. Tighten the input line if necessary; (4) Decrease the temperature. Check the fan and clean the duct. (5) Decrease load; (6) Decrease rectifying load current crest factor (for example, connect a serial reactor in the rectifying load circuit) or increase

		capacity of power unit.
E200 E201	(1) Input wiring error or contact problem (2) Power line diameter is too small or too large line resistance (3) Input supply voltage is abnormal (4) Internal busbar voltage too high	(1) Check the input wiring (2) Select appropriate input power wire based on the capacity, and check if the input line is loose (3) Ensure the input power voltage is within $220 \pm 33V$ (4) Check the output load (check for re-charge energy at output of power supply)
E311 E341 E371 E314 E344 E374 E315 E345 E375	(1) Internal components or wiring fallen off for long time (2) Anomalies caused by load or operation	(1) Check for wrong wiring from the front door without opening the chassis (2) Shut down the machine and restart. Operate following the specification.

## 6.3 Storage and Transportation

### 6.3.1 Storage

- Indoor storage;
- No flammable and corrosive media;
- No significant vibration and shock;
- No rain or dripping;
- Temperature:  $-10^{\circ}C \sim +50^{\circ}C$ ;
- Humidity: 0~90%RH, no condensate;
- Ambient pressure: 70~106 kPa;

Vibration: maximum 0.3mm (2~9Hz), 1m/s<sup>2</sup> (9~200Hz), Sine (IEC 68-2-6);

Environment impact: maximum 100m/s<sup>2</sup>, 11ms (IEC 68-2-27).



### Caution

Dustproof during storage. Never put any objects on the unit.

## 6.3.2 Transportation

### 6.3.2.1 Package

Only use original package for repair or transportation, otherwise, pack the unit as following:

Pack the unit in a plastic bag;

Put the unit in a wooden container or paper box with capacity suitable for the power supply (See the column Weight in Table 1-1);

Fill vibrating-proof materials (2mm). Protect the panels using thick foam;

Seal the container. **Mark “Be careful” clearly.**



### Caution

**For repair, pack all accessories (power line and test line etc) together with the unit, and note the fault.**

### 6.3.2.2 Transportation

Rail and road transport are available. No rain, heat, upside-down during transportation. No rollover, drop or strong vibration during loading/unloading.

## Chapter 7 Remote Communication/Control

### Guide:

- Protocol
- Interfaces
- Analog Control

### 7.1 Protocol

#### 7.1.1 Handshake Protocol

In the test/control network (Figure 7-1) consisting of the master and the slave, communication is initiated by the master, and the slave will answer, adopting one-way handshake protocol. Only the upload data from the slave contains the information about if the data received by the master is correct. The master will determine whether to re-send the control command based on this information. After receiving the data uploaded from the slave, the host will determine whether the uploaded data is correct according to checksum. If it is incorrect, re-send the command to the slave.

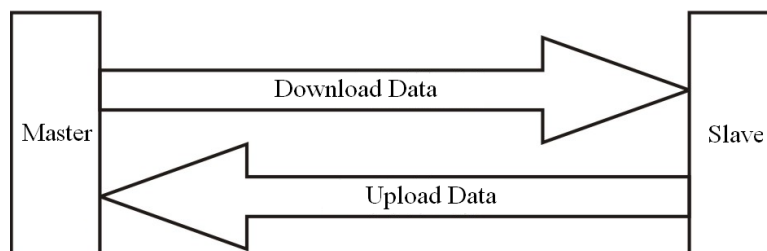

Figure 7-1 Handshake protocol

#### 7.1.2 Protocol Agreement

- 1) The PC is the master by default, and the standard unit is the slave, adopting Master-Slave answer mode. The slave shall not send data to the master if there is no special explicit command.
- 2) Baudrate: 1200, 2400, 4800, 9600, 19200, 38400. Default: 38400.
- 3) Address: 1~255.
- 4) Format of data frame: bit-1: start; bit-8: data, 1 stop bit, total 10 bits.
- 5) After the slave receives the valid command, the keyboard is locked.
- 6) In soft start state, there is no respond to the command.

7) In analog control state, there is no respond to the command.

**Note:** For communicate between PC and the power supply, as there is large software running or firewall at PC, the communication response measured at the PC side is slow. For faster communication, shut down large software or firewall as possible.



**Note:** For communication between the machine and the PC, make sure that: the address of power supply shall be consistent with that in the command!

### 7.1.3 Receive Protocol and Frame Format

Table 7-1 Frame format

Frame Header	Total bytes	Slave address	Command			Checksum	End of Frame
			Class	Word	Parameter		
0x7B	XX	X	X	X	XXXXXX	X	0x7D

Note: 1. Each **X** represents a byte.

2. The bytes of command parameter is different based on the length of the command parameters.

- Frame Header: 1 byte, fixed 0x7B, '{' ASCII code.
- Total bytes: 2 bytes. Value: the sum of Frame Header + total bytes+ slave address + Command Class + Command Word+ Command Parameter + Checksum + End of Frame bytes, high bytes at the beginning, and low bytes following.
- Address: 1 byte, address of the machine.
- Command: the length of bytes is different. See "Description of Command".
- Checksum: 1 byte (hexadecimal), the check result of sent data. Adopt level check, that is the sum of bytes + slave address + command. Take the low bytes as the checksum.
- End of Frame: 1 byte, fixed 0x7D, '}' ASCII code.

### 7.1.4 Send Protocol

The frame format is shown in Table Table 7-1.

- Command type: type of the command as a correct command is received. For received wrong command, the command type is 0x99.
- Command word: the received command word.
- Arguments:
  - As a correct query command is received, the argument of the answer command is the query result, and the number of bytes is determined based on the command.
  - As a wrong query class command is received, the argument will be the error code with one byte. The slave shall return error data to the master after receiving a wrong command from the master.
  - As a correct command other than query class is received, the command type and word of the previously received command will be returned with returned argument 0x00.

Table 7-2 Error codes

Error code	Error data	Remark
0x01	Checksum error	

0x02	Command type error	This type of command not covered by the protocols
0x03	Command word error	The command word not covered by the protocols
0x04	State error	The received command can't be performed in current stat, returning this error code
0x05	Arguments error	Arguments invalid or number error
0x06	Protection alarm	Return this code for control command and online adjustment command in alarm state
0x07	Over-range	The arguments measurement exceeding current range.

## 7.1.5 List of Commands

Table 7-3 List of commands

Command Class	Command			Function
	Type	Word	Argument	
Control	0x0F	0x00	No	STOP
		0xFF	No	Start
		0x03	No	Release alarm
Query	0xF0	0x11	No	Query U-phase output (3-phase power supply) /Query output ( single-phase power supply)
		0x12	No	Query V-phase output (only 3-phase power supply)
		0x13	No	Query W-phase output (only 3-phase power supply)
		0xAE	No	Query all outputs (only 3-phase power supply)
		0xEB	No	Query instrument state/alarm code
		0xED	No	Query model of instrument
Query of Setting	0xA5	0x11	No	Query current group
		0x21	X*1	Query setting of group parameters
		0x30	No	Query setting of system parameters
Set	0x5A	0x11	X*1	Set current group
		0x21	X*9	Set group parameters, and set the group setting to current group
		0x30	X*8	Set system parameters

		0x50	X*4	Online voltage/frequency adjustment
--	--	------	-----	-------------------------------------

## 7.1.6 Commands

### 7.1.6.1 Control Command (0x0F)

#### Command word: 00H

Function: STOP  
 Format: 0x7B XX X **0x0F** **0x00** X 0x7D (8 bytes)  
 Example: 7B 00 08 01 0F 00 18 7D

#### Command word: FFH

Function: Start  
 Format: 0x7B XX X **0x0F** **0xFF** X 0x7D (8 bytes)  
 Example: 7B 00 08 01 0F FF 17 7D

#### Command word: 03H

Function: STOP Alarm  
 Format: 0x7B XX X **0x0F** **0x03** X 0x7D (8 bytes)  
 Example: 7B 00 08 01 0F 03 1B 7D

### 7.1.6.2 Query Command (0xF0)

#### Command word: 11H

Function: Query U-phase output measurement: voltage, current, frequency, power (Query output for single-phase power supply)  
 Format: 0x7B XX X **0xF0** **0x11** X 0x7D (8 bytes)  
 Example: 7B 00 08 01 F0 11 0A 7D  
 Answer Format: 0x7B XX X **0xF0** **0x11** X (3-phase power supply output mode: 0: standard output; 2: phase-A output; 3: phase-B output; 4: phase-C output; invalid for single-phase power supply) XX XX XX XXX (2 bytes voltage in 0.1V, 2 bytes current in 0.1A, 2 bytes frequency in 0.1Hz, 3 bytes power in 1W) X 0x7D (18 bytes)

#### Command word: 12H

Function: Query V-phase output measurement: voltage, current, frequency, power (N/A for single-phase power supply)  
 Format: 0x7B XX X **0xF0** **0x12** X 0x7D (8 bytes)  
 Example: 7B 00 08 01 F0 12 0B 7D (Answer Format the same as 11H Command word)

#### Command word: 13H

Function: Query W-phase output measurement: voltage, current, frequency, power (N/A for single-phase power supply)  
 Format: 0x7B XX X **0xF0** **0x13** X 0x7D (8 bytes)  
 Example: 7B 00 08 01 F0 13 0C 7D (Answer Format the same as 11H)

Command word)

**Command word: AEH**

Function: Query UVW-phase output measurement: voltage, current, frequency, power (N/A for single-phase power supply)

Format: 0x7B XX X 0xF0 0xAE X 0x7D (8 bytes)

Example: 7B 00 08 01 F0 AE A7 7D

Answer Format: 0x7B XX X 0xF0 0xAE X (3-phase power supply output mode: 0: standard output; 2: phase-A output; 3: phase-B output; 4: phase-C output; invalid for single-phase power supply) XXXXXXXXXX (2 bytes voltage in 0.1V, 2 bytes current in 0.1A, 2 bytes frequency in 0.1Hz, 3 bytes power in 1W, the same for later two blocks) X (output mode as above) XXXXXXXXXX (measurement, with same format as above) X (output mode as above) XXXXXXXXXX (measurement, with same format as above) X 0x7D (38 bytes)

**Command word: EBH**

Function: Query instrument state/alarm code

Format: 0x7B XX X 0xF0 0xEB X 0x7D (8 bytes)

Example: 7B 00 08 01 F0 EB E4 7D

Answer Format: 0x7B XX X 0xF0 0xEB XXX (1 byte state + 2 bytes additional data: Standby: 0x83+0+0/Output Setting: 0x84+0+0/Start Ramp: 0x85+ output mode <sup>Note 1</sup>: X +0/output: 0x86+ output mode: X+0/Alarm: 0xA+XX Alarm Code/System Setting: 0xD0+0+0) X 0x7D (11 bytes)

Note 1: Output mode: 0: standard 3-phase output \2: U-phase single\3: V-phase single \4: W-phase single\5: single-phase power supply output

**Command word: EDH**

Function: Query model of instrument

Format: 0x7B XX X 0xF0 0xED X 0x7D (8 bytes)

Example: 7B 00 08 01 F0 ED E6 7D

Answer Format: 0x7B XX X 0xF0 0xED XXXXXXXXXXXXXXXXXXXX (16 bytes ASCII code, e.g., "ANFC090T(F)", "ANFC090S(F)". Supply with a space if the model is less than 16 bytes) X 0x7D (24 bytes)

**7.1.6.2 Set Command (0x5A)****Command word: 11H**

Function: Set current group

Format: 0x7B XX X 0x5A 0x11 X (1 byte Group No.: 0~6) X 0x7D (9 bytes)

Example: 7B 00 09 01 5A 11 02 77 7D

**Command word: 21H**

Function: Set group parameters, and set the group setting to current group  
 Format: 0x7B XX X 0x5A 0x21 XXXXXXXXXXX (1 byte Group No.: 0~6, 1 byte output mode, set to 5 for single-phase power supply, 2 bytes phase voltage, 2 bytes frequency, 1 byte increase, 1 byte decrease, 1 byte Auto 0/High 1) X 0x7D (17 bytes)  
 Example: 7B 00 11 01 5A 21 01 00 00 64 02 01 09 07 01 06 7D

**Command word: 30H**

Function: Set system parameters  
 Format: 0x7B XX X 0x5A 0x30 X XX XX XX X (1 byte: voltage output mode – phase (0)/line (1) voltage, set to 0 for single-phase power supply, 2 bytes: OCP 0~ rated current, set to 0 for closing OCP function, 2 bytes Start Ramp Time 0.0~99.9s, 2 bytes voltage compensation 0.000~0.500, 1 byte key tone 0 (OFF)/1 (ON) X 0x7D (16 bytes)  
 Example: 7B 00 10 01 5A 30 01 00 64 00 64 00 32 00 96 7D

**Command word: 50H**

Function: Online voltage/frequency adjustment  
 Format: 0x7B XX X 0x5A 0x50 XXXX (2 bytes voltage, 2 bytes frequency) X 0x7D (12 bytes)  
 Example: 7B 00 0C 01 5A 50 04 4C 01 F4 FC 7D

**7.1.6.2 Query of Settings (0xA5)****Command word: 11H**

Function: Query current group  
 Format: 0x7B XX X 0xA5 0x11 X 0x7D (8 bytes)  
 Example: 7B 00 08 01 A5 11 BF 7D  
 Answer Format: 0x7B XX X 0xA5 0x11 X (1 byte Group No.: 0~6) X 0x7D (9 bytes)

**Command word: 21H**

Function: Query group parameters  
 Format: 0x7B XX X 0xA5 0x21 X (1 byte Group No.: 0~6) X 0x7D (9 bytes)  
 Example: 7B 00 09 01 A5 21 03 D3 7D  
 Answer Format: 0x7B XX X 0xA5 0x21 XXXXXXXXXXX (1 byte Group No.: 0~6, 1 byte output mode, 2 bytes phase voltage, 2 bytes frequency, 1 byte increase, 1 byte decrease, 1 byte Auto (0)/High (1)) X 0x7D (17 bytes)

**Command word: 30H**

Function: Query system parameters

Format: 0x7B XX X 0xA5 0x30 X 0x7D (8 bytes)

Example: 7B 00 08 01 A5 30 DE 7D

Answer Format: 0x7B XX X 0xA5 0x30 X XX XX XX X (1 byte: voltage output mode - phase (0)/line (1) voltage, 2 bytes: OCP 0~ rated current, set to 0 for closing OCP function, 2 bytes Start Ramp Time in 0.1 Sec., 2 bytes voltage compensation in 0.001  $\Omega$ , 1 byte key tone 0 (OFF)/1 (ON)) X 0x7D (16 bytes)

## 7.2 Interfaces

This power supply supports 4 types of interfaces: RS232, RS485, GPIB and Ethernet, and only one channel. The user shall select the type of interfaces (only one) in the order: RS232, RS485, GPIB or Ethernet, and cannot change it freely.

### 7.2.1 RS232/RS485



**Note:** This machine has only one type of interface: 232 or 485, which shall be consistent with that in the order!



**Note:** For communication between the power supply and PC, make sure that:  
The address of power supply shall be consistent with that in the command!

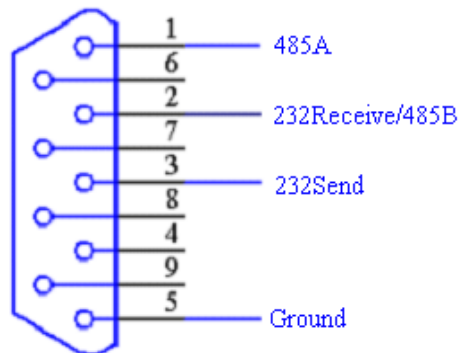

Figure 7-2 9-pin D-sub socket

(1) 9-pin D-sub socket. The definition of pins is as shown in Figure 7-2:

(2) Definition of pins:

- Pin-1--485A
- Pin-2--232RXD/485B
- Pin-3--232TXD
- Pin-5--GND

### 7.2.2 GPIB

GPIB standard interface, as shown in Figure 7-3:

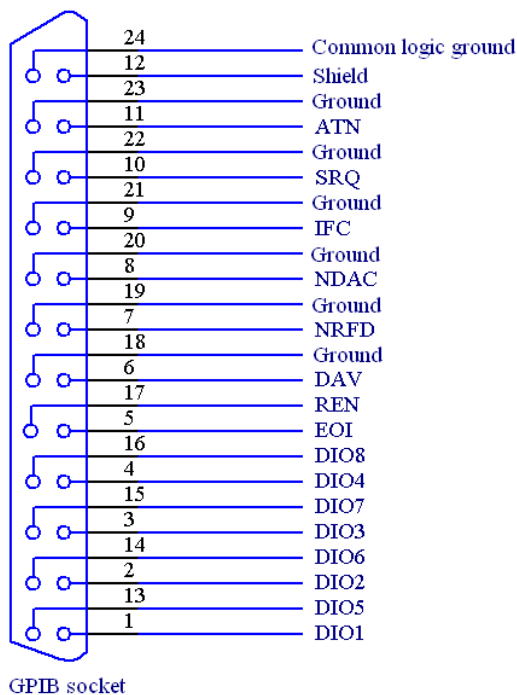

Figure 7-3 Pins of GPIB socket

## 7.2.3 Ethernet

- (1) Standard network interface.
- (2) The IP address of power supply as ex-factory is 192.168.0.253. The subnet mask is 255.255.255.0, and the port number is 10001. To use customized IP address or port number, the user shall designate in the order or obtain support from the customer service center.
- (3) The same as a PC, the power supply shall be connected with a network via a route and straight cables; or with a PC directly via a crossover cable for communication. The straight cables and crossover cables are prepared as shown in Figure 7-4:

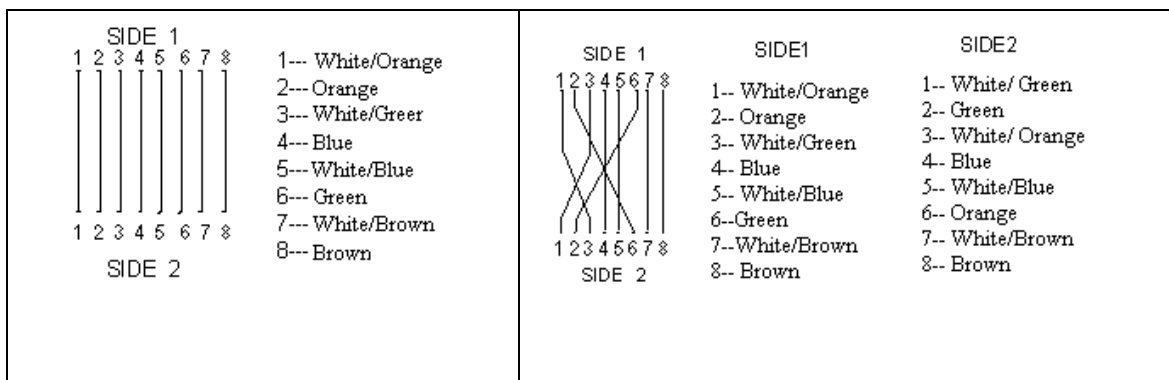

Figure 7-4 Wiring of straight cables (left) and crossover cables (right)

## 7.3 Analog Control

### 7.3.1 Analog Control Panels

For power supply with analog control, click 456+Set in the Standby screen to enter Analog Control screen, as shown in Figure 7-5 and Figure 7-6. The LEDs of shortcut 1~6 are ON.

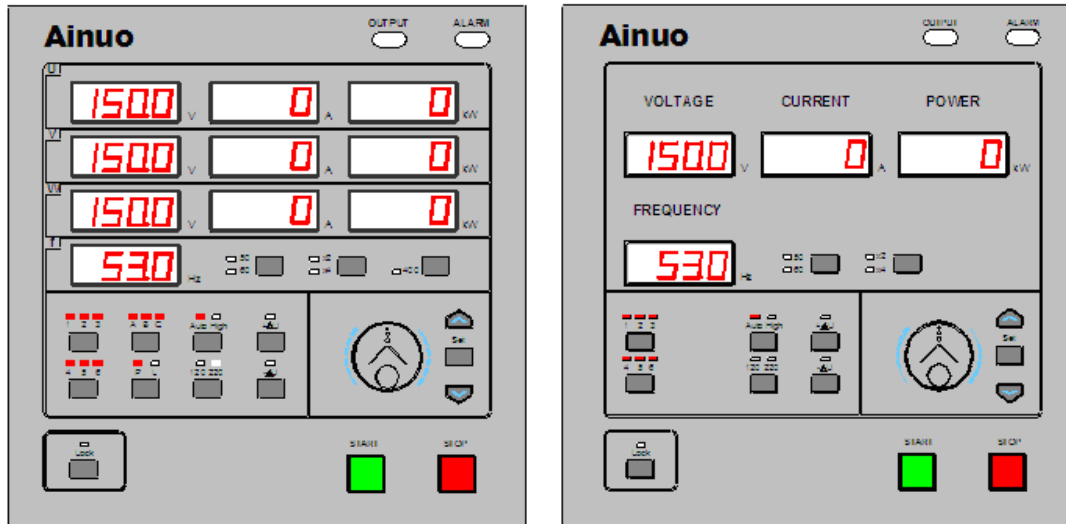

Figure 7-5 Analog Control of 3-phase power supply Figure 7-6 Analog Control of single-phase power supply

### 7.3.2 Analog Control screen 下的 panel operation

Click *STOP* key to exit Analog Port Control screen and return to Standby screen.

(Only 3-phase power supply) Click *U V W* key to switch between output modes: UVW-phase, U-phase single, V-phase single, W-phase single.

Click *Lock* key to enter Lock screen (Lock LED illuminates) and exit Lock screen (Lock LED goes off)



**Note:** The analog control state is not affected by communication, nor by any keys other than the above ones. It is only controlled by the input signal from the analog control port.

### 7.3.3 Pins of Analog Control Socket

The analog control socket is 25-pin interface. The pins are defined as shown in Figure 7-7.

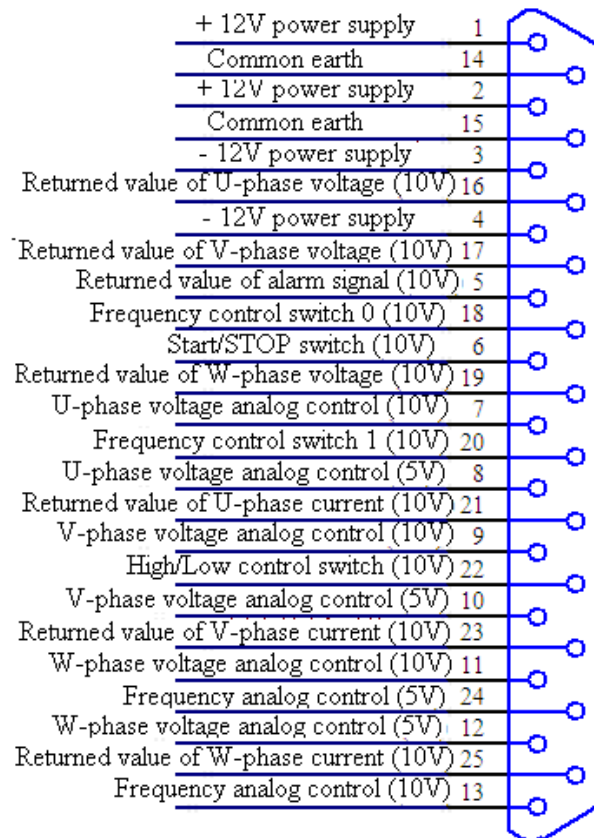

Figure 7-7 Definition of pins of analog control socket



### Notice

**The + 12V/-12V power supply are used for debugging and maintenance of the power supply. Do not connect this power supply with external wiring, otherwise, the analog control interface may be damaged.**

### 7.3.4 Control and Detection of Analog Control Interface

Table 7-4 List of analog control pin control and detection

Pin	Type	Definition	Meaning (valid in analog control state)
6	Input digital control (10V)	Start/STOP switch	The input '10V' represents start of the power supply. The input '0V' represents stop of the power supply. During alarm in analog control state, the input changes from '10V' to '0V' to stop the alarm.
18		Frequency control switch 0	For frequency switch <sup>Note 1</sup> 11 or 00, the analog control frequency setting is controlled by the frequency analog control signal;
20		Frequency control switch 1	For frequency switch 01, the analog control frequency setting is always locked at 50.0Hz; For frequency switch 10, the analog control frequency setting is locked at 60.0Hz;
22		High/Low control switch	The input '10V' represents start of the power supply. The input '0V' represents stop of the power supply. During alarm in analog control state, the input changes from '10V' to '0V' to stop the alarm.
13	Input analog control (10V/5V)	Frequency control (10V)	Analog 0~10V/0~5V represents 45.0~65.0Hz. Either 10V interface or 5V interface is valid at one time.
24		Frequency control (5V)	
7		U-phase voltage control (10V)	Analog 0~10V/0~5V represents 0.0~300.0V. Either 10V interface or 5V interface is valid at one time.
8		U-phase voltage control (5V)	In 3-phase U/V/W output mode, this analog will control U/V/W 3-phase voltage. For single-phase power supply, only this analog interface is valid.
9		V-phase voltage control (10V)	Analog 0~10V/0~5V represents 0.0~300.0V. Either 10V interface or 5V interface is valid at one time.
10		V-phase voltage control (5V)	Valid only in 3-phase power supply V-phase output mode.
11		W-phase voltage control (10V)	Analog 0~10V/0~5V represents 0.0~300.0V. Either 10V interface or 5V interface is valid at one time.
12		W-phase voltage control (5V)	Valid only in 3-phase power supply W-phase output mode.
16	Analog Detection (10V)	Returned value of U-phase voltage	Analog 0~10V represents 0.0~300.0V.
17		Returned value of V-phase voltage	Analog 0~10V represents 0.0~300.0V.
19		Returned value of	Analog 0~10V represents 0.0~300.0V.

		W-phase voltage	
21		Returned value of U-phase current	Analog 0~10V represents 0.0~ Low rated current. For 90kVA 3-phase power supply, represent 0.0~272.7A. For 90kVA single-phase power supply, represent 0.0~818.2A
23		Returned value of V-phase current	Analog 0~10V represents 0.0~ Low rated current.
25		Returned value of W-phase current	Analog 0~10V represents 0.0~ Low rated current.
5	Digital Detection (10V)	Returned value of alarm signal	Return 10V in alarm state, and 0V in non-alarm state.

Note 1: The switch 11 means both frequency control switch 0 and 1 are set as 10V; switch 00 means both frequency control switch 0 and 1 are set as 0V; switch 01 means frequency control switch 0 is set as 10V, and frequency control switch 1 is set as 0V; switch 10 means frequency control switch 0 is set as 0V and frequency control switch 1 is set as 10V.

## 7.4 Software(Optional)

AC power supply can be used to combine with software(Figure 7-8) to realize comprehensive functions.

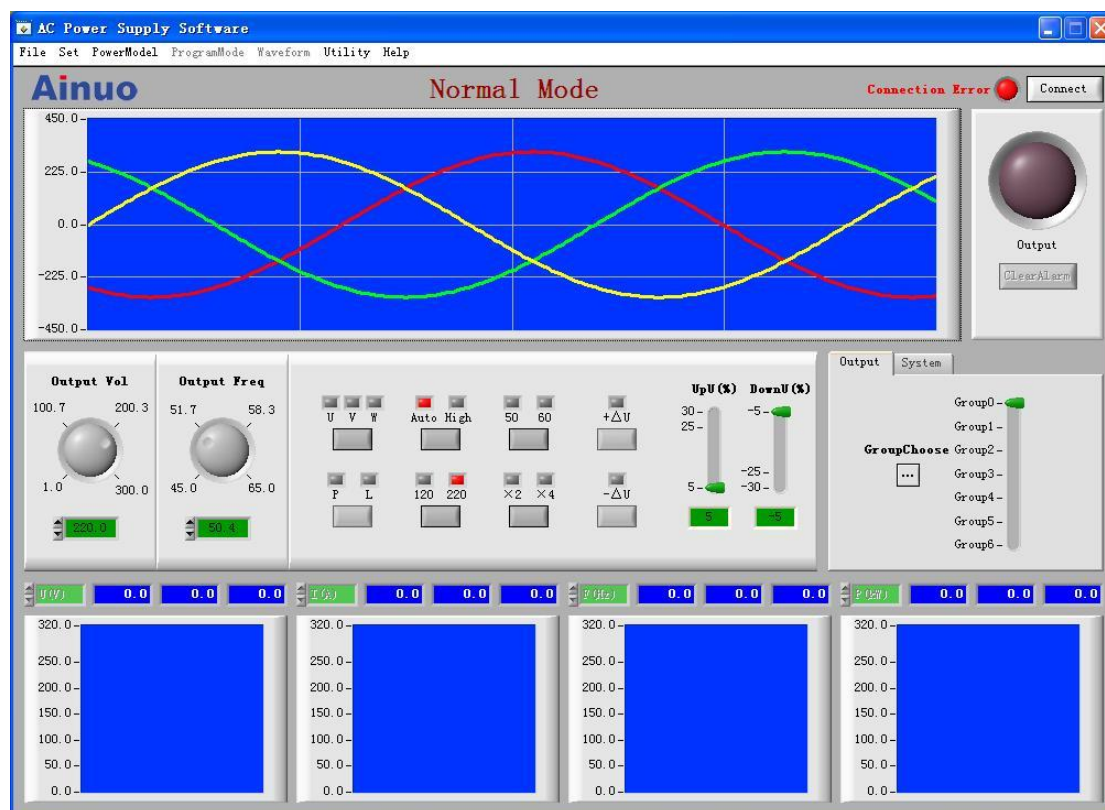

Figure 7-8 AC power supply software

**Annex I Table of Alarm Codes**

Table I -1 Fault codes

No.	Fault code	Fault name	Remark
1	E410	U-phase module overheating	U-phase IGBT module overheating protection/sampling fault
2	E440	V-phase module overheating	V-phase IGBT module overheating protection/sampling fault
3	E470	W-phase module overheating	W-phase IGBT module overheating protection/sampling fault
4	E412	U-phase module overcurrent	U-phase IGBT module overcurrent
5	E442	V-phase module overcurrent	V-phase IGBT module overcurrent
6	E472	W-phase module overcurrent	W-phase IGBT module overcurrent
7	E500	Transformer overheating	Any phase of U/V/W 3-phase transformer overheating protection
8	E200	Input over/undervoltage	Input voltage exceeding 220V $\pm$ 15% (33V)
9	E201	Bus line voltage high	Internal bus voltage exceeding 650V
10	E311	U-phase output overvoltage	U-phase output voltage higher than 315V or the setting 10V
11	E341	V-phase output overvoltage	V-phase output voltage higher than 315V or the setting 10V
12	E371	W-phase output overvoltage	W-phase output voltage higher than 315V or the setting 10V
13	E312	U-phase output overcurrent	U-phase output current higher than the rating
14	E342	V-phase output overcurrent	V-phase output current higher than the rating
15	E372	W-phase output overcurrent	W-phase output current higher than the rating
16	E313	U-phase output overload	U-phase output power higher than the rating
17	E343	V-phase output overload	V-phase output power higher than the rating
18	E373	W-phase output overload	W-phase output power higher than the rating
19	E314	U-phase output	U-phase output voltage lower than the setting 10V

		undervoltage	
20	E344	V-phase output undervoltage	V-phase output voltage lower than the setting 10V
21	E374	W-phase output undervoltage	W-phase output voltage lower than the setting 10V
22	E315	U-phase output phase failure	U-phase output phase failure in standard 3-phase output mode
23	E345	V-phase output phase failure	V -phase output phase failure in standard 3-phase output mode
24	E375	W-phase output phase failure	W -phase output phase failure in standard 3-phase output mode

Note: The alarm codes of 3-phase power supply and single-phase power are the same, for the hardware modules are the same. Therefore, phase-V or phase-W alarm code for single-phase power supply means internal line-2 or line-3 failure.